

Eco-lution

High Performance Air-Conditioning



FD series

Inverter Packaged Air-Conditioners

50/60Hz
10P01E-A-0

Hyper Inverter

Our new advanced technology has realized high efficiency, strong heating and long piping.

This contributes to the environmental protection through energy saving and permits installation of the units (4~6HP) considering a heating operation under temperature conditions down to -20°C and design flexibility has been improved by extension of piping length to 100m.



Line up

	HP									
	1.5	2	2.5	3	4	5	6	8	10	
Hyper Inverter	●	●	●	●	●	●	●			

High efficiency

The industry's highest COP levels are achieved by our latest technologies, such as new high efficient twin rotary compressors and the combination with new Hyper inverter outdoor units.

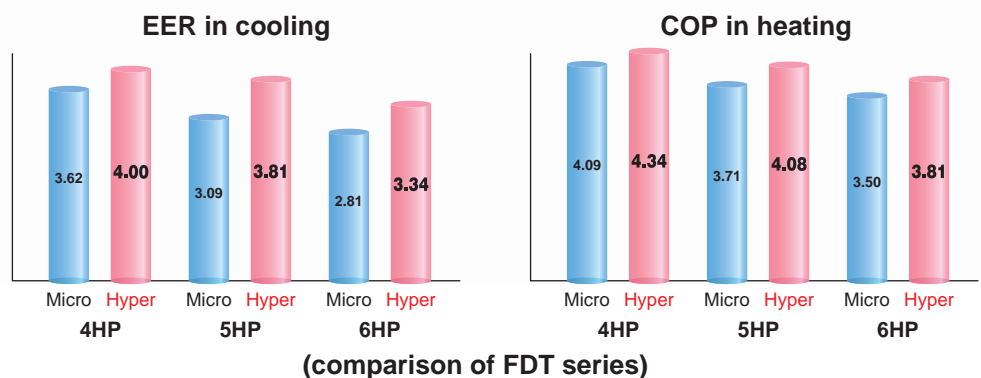

Long piping

(in case of 4~6HP)

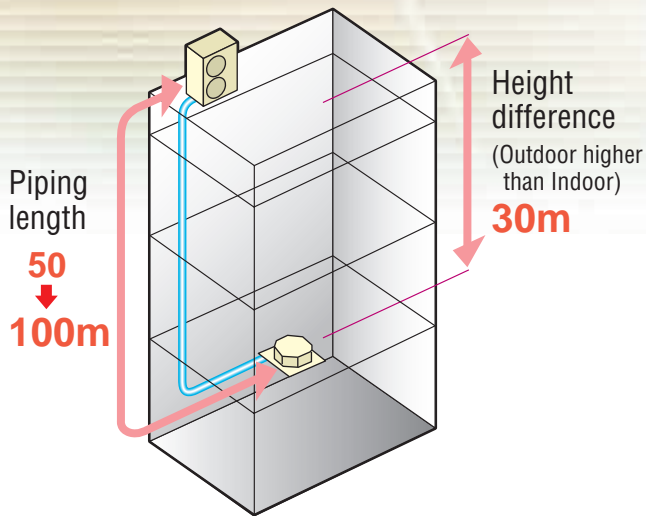

Strong heating

(in case of 4~6HP)

-20°C: Heating operation down to -20°C
-15°C: Nominal heating capacity maintained at -15°C

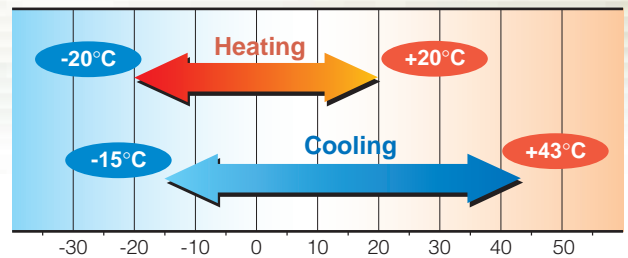

Max.heating capacity (kW)

	Hyper Inverter	Micro Inverter
FDC100VSX(4HP, 3phase 380V)	16.0	12.5
FDC125VSX(5HP, 3phase 380V)	18.0	16.0
FDC140VSX(6HP, 3phase 380V)	20.0	16.5

Leading powerful heating capacity in the industry

Thanks to optimization of refrigeration control with use of electric expansion valve and development of new twin rotary compressors, max heating capacity has been increased.

Hyper Inverter series can reach the set temperature very quickly, keeping nominal heating capacity when outdoor temperature is -15°C. It is effective to be used even in cold area.

Temperature of supply air can reach 40°C in 4 minutes after start up under low temperature operation conditions (at both indoor and outdoor temperature of 2°C) and can reach 50°C in 8 minutes after that.

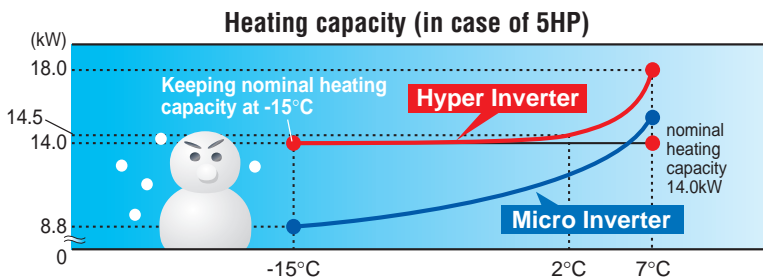

model name	nominal heating capacity (kW at outdoor temperature of 7°C)	heating capacity at outdoor temperature of -15°C
FDT100VSX(4HP, 3phase 380V)	11.2kW	11.2kW
FDT125VSX(5HP, 3phase 380V)	14.0kW	14.0kW
FDT140VSX(6HP, 3phase 380V)	16.0kW	16.0kW

Please refer to our technical manual for installation conditions, operation range and heating/cooling capacities.

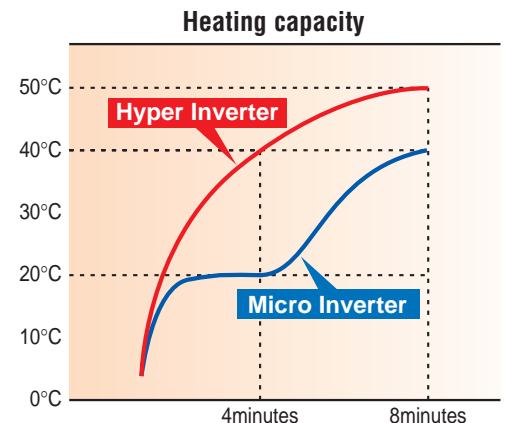

Micro Inverter

Compact Design of outdoor units

Line up

	1.5	2	2.5	3	4	5	6	8	10
Micro Inverter					●	●	●	●	●



FDC100VN/VS (4.0HP)
FDC125VN/VS (5.0HP)
FDC140VN/VS (6.0HP)

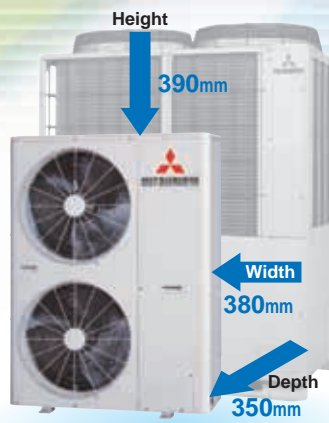

FDC200VS (8.0HP)

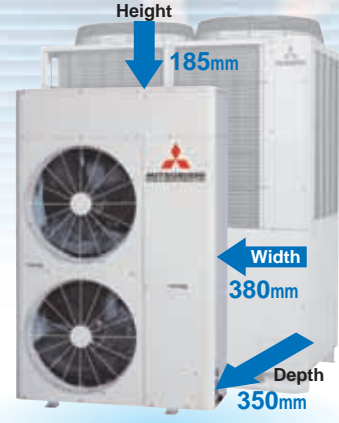

FDC250VS (10.0HP)

Easy installation

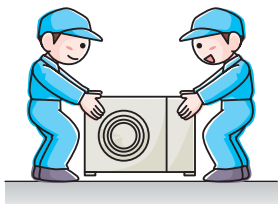

Reduction in weight (kg)

	Former model	New model	*Reduction
4.0HP	82	74	-8
5.0HP	118	74	-44
6.0HP	125	74	-51
8.0HP	225	122	-103
10.0HP	225	140	-85

* Comparison with former models

Fits into elevators



Reduction in volume (%)

	Former model	New model	*Reduction
4.0HP	328	303	8%
5.0HP	467	303	35%
6.0HP	467	303	35%
8.0HP	1643	467	72%
10.0HP	1643	540	67%

* Comparison with former models

Size reduction and high efficiency performance on the DC twin rotary compressors

(Micro Inverter 4-6HP)

Employment of DC twin rotary compressor has enabled to utilize a high-speed range of up to 120 rps at the maximum to secure the required capacity.

Optimum compressor control has been realized by employing the vector control* and the starting current has been improved significantly compared with former models. Moreover, vibration has been reduced.

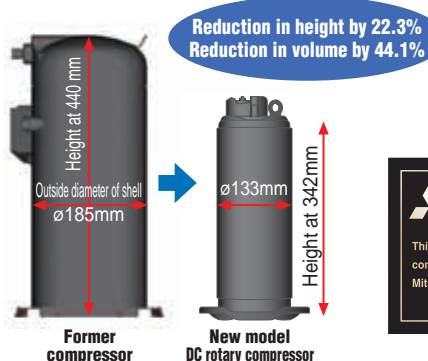

* Vector control means a technique to realize an optimum control by converting the current wave to a smooth sinusoidal waveform



Improved efficiency of heat exchanger

Redesigning the fins to a straight shape has reduced the pressure loss of the airflow in the heat exchanger. Surface treatment on the fin has enhanced the frost resistance capacity compared with former models.

Owing to the reduction in the size of heat exchanger, the appropriate number of circuits for each HP has been applied. Employment of a high-speed motor has increased the airflow and enabled to keep the cooling capacity under a condition of higher outdoor air temperatures*.

* Limitation of use is around 43°C at the maximum.

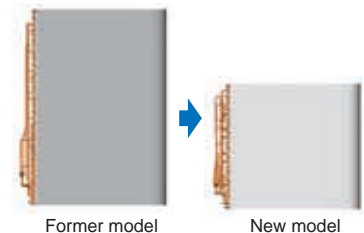

Controllability

Reliability in the protection of compressor has been improved by optimizing the controls of oil return, electronic expansion valve, etc.

High technology

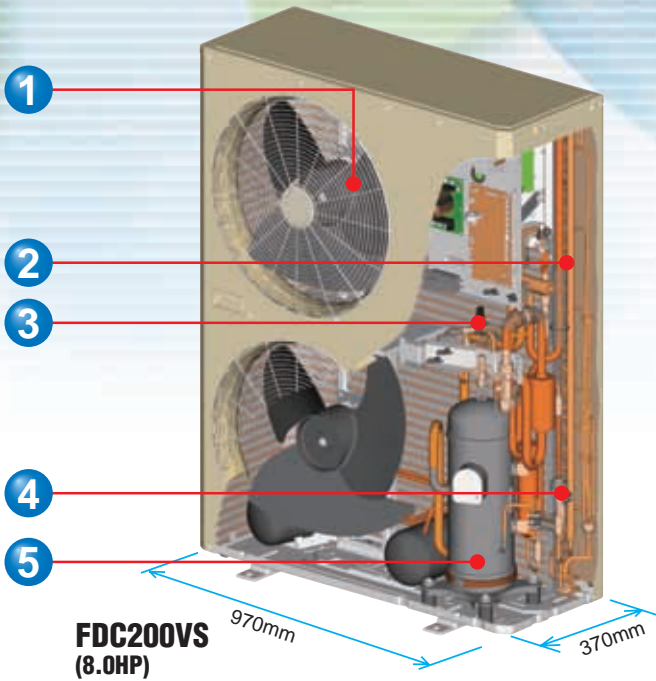

POINT
1

DC fan motor uses less energy

POINT
2

Optimization of heat exchanger path.
More efficient heating and cooling

POINT
3

Super heat control with low pressure
sensor, works better in tough conditions

POINT
4

High efficiency refrigeration circuit

POINT
5

Newly developed High efficiency DC
scroll compressor

Employment of the scroll inverter compressors (8/10HP)

A control over wide range of capacity and a high efficiency has been realized by inverter-driven scroll compressors. In addition, the starting current significantly is improved. The size has also been reduced by 3.2% in height and 31.8% in volume.

Employment of DC fan motor

Employment of DC fan motor has enabled to realize an excellent efficiency of approx. 60% higher than former models.

Wide range of operation

Our new advanced technology has expanded the heating and cooling operation range. This permits installation of the units under a low outdoor temperature conditions down to -20°C in heating operation and -15°C in cooling operation.

(FDC 100/125/140)

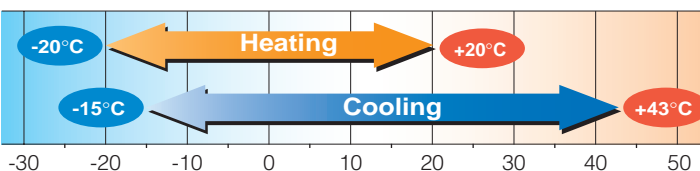

Energy labeling "Class A"

MHI models have cleared the class A standard, the highest energy saving level, with their high COP (coefficient of performance).

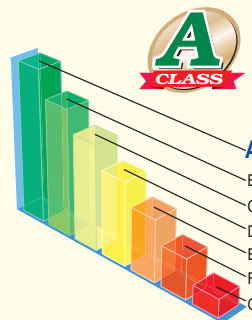

Energy		Air-conditioner
Manufacturer		
Outside unit		
Inside unit		
More efficient		
A		
B		
C		
D		
E		
F		
G		
Less efficient		
Annual energy consumption, kWh in cooling mode		
<small>(Actual consumption will depend on how the appliance is used)</small>		
Cooling output	kw	
Energy efficiency ratio		
<small>Full load (the higher the better)</small>		
Type	Cooling only	—
	Cooling + Heating	—
	Air cooled	—
	Water cooled	—
Heat output		kw
Heating performance		
A: higher G: lower		
Noise		
<small>(dB(A) re 1 pW)</small>		
<small>Further information is contained in product brochures</small>		
<small>Air-conditioner Energy Label Directive 2002/31/EC</small>		

Ceiling Cassette -4way- Indoor units

FDT-FDTC

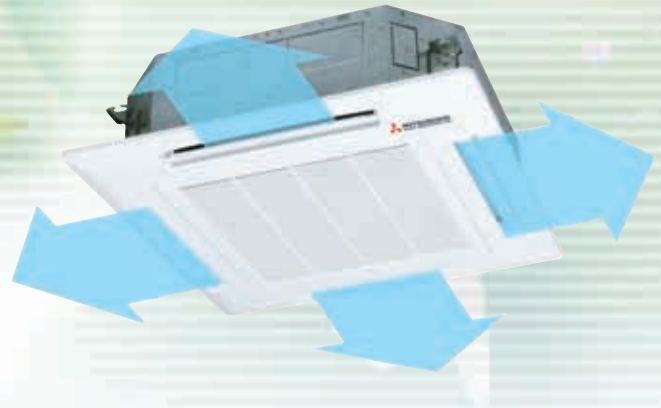

Individual flap control system

According to room temperature conditions, four directions of air flow can be controlled by individual flap as preferred. As individual flap control is available even after installation, installation area became wider than before.



Due to optimization of outlet design of air flow with our new advanced technology, sufficient air flow is secured and long reach of air flow is realized.(FDT)

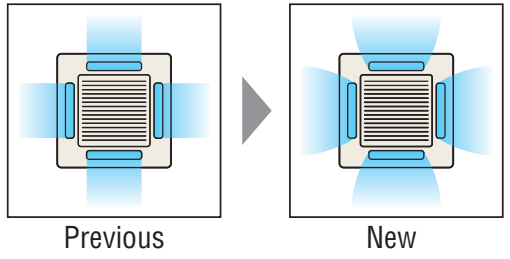

Flap control system

Selection of louver position is possible. Louvers can be set at different angles.

*RCH-E3 is not applicable to the Individual flap control system and the Flap control system.

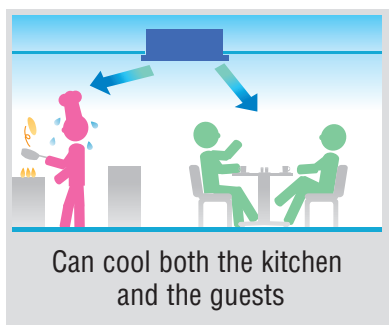
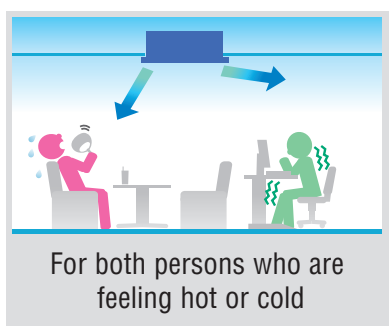
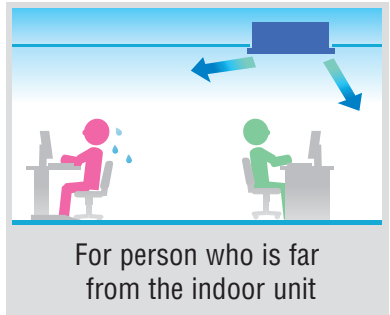
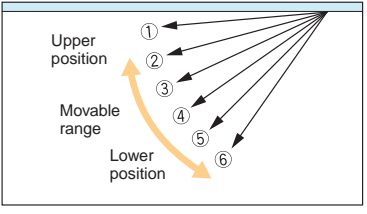

The thinnest design

Thanks to new design of heat exchanger changed from 2 parts to 1 part, the height of indoor unit is reduced drastically.

Furthermore applying DC fan motors, the highest energy efficiency level, reduction of weight and significant compact design are realized.

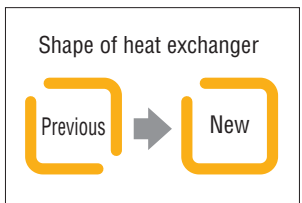
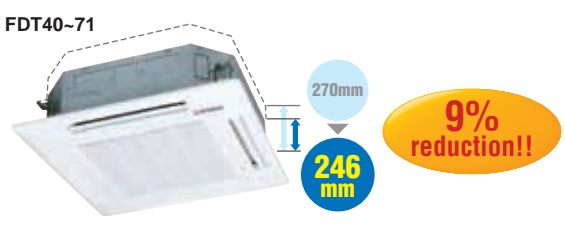
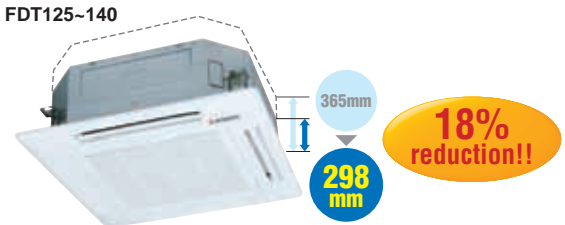

High efficiency

• Reduction of air flow pressure loss

Expansion of outlet air flow area realizes reduction of pressure loss caused by air flow in the indoor unit. Load of fan motor is decreased and efficiency is increased.

• Increase of heat transfer efficiency

Applying high efficient piping in heat exchanger and optimization of heat exchanger (2parts → 1part) increases heat transfer efficiency.

Achieved COP 5.67

based on 50% capacity of FDT100V in heating operation

Air-conditioners are generally selected with the operation under the most severe ambient temperature conditions.

The inverter constantly adjusts compressor output to meet the exact demand of the indoor units.

i.e. In case that selecting the capacity of an inverter air-conditioner based on heating operation at -5°C, its capacity drops by 50% at 7°C(ISO-TI measurement condition) and operation period at 50% capacity is normally longer than that at 100% of nominal heating capacity.

Considering annual electrical power consumption of inverter air-conditioners, it is quite important to give the first priority to 50% actual capacity and selecting inverter air-conditioners is the best solution for saving energy and protecting the environment.

Convenience

Signal output

A dry contact is equipped on an indoor unit to meet a possible need for signal output on the site.

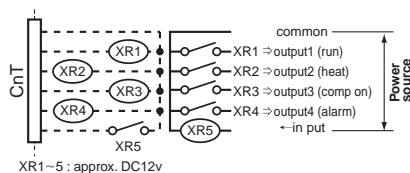

Monitoring Function

Equipped with RS232C for connection directly to your PC monitoring and service tasks made simple with our service software ("Mente PC").

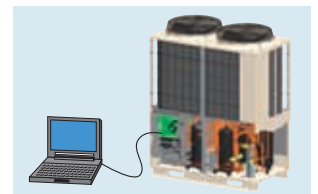

New remote control

Applying nonpolar 2-core in new remote control line for all indoor units, it is very convenient for installation including renewal case.



Consideration on the Environment

All models employ R410A, with RoHS* directive

Employment of lead-free solder

Adapt to RoHS

In order to comply with RoHS standard, the new inverter series products use lead-free solder. It was considered to be too difficult to use lead-free solder because it requires higher soldering temperatures at assembling, which could jeopardize the reliability of assembly, etc. PbF soldering method developed by us, however, has enabled a higher reliability for lead-free printed circuit boards.

*"RoHS" is the abbreviation of the new European standard, which means Restriction of Hazardous Substances.

Employment of the new refrigerant















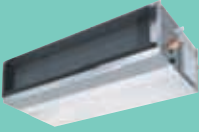
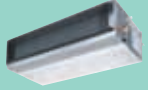

All models of the New inverter series use a new refrigerant R410A characterized by the ozone depletion coefficient being 0.

R410A













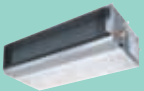



Energy Conservation

A High Performance and Excellent Energy Conservation are achieved at the same time by an increased capacity of heat exchanger and employment of high efficiency DC motor etc.

SINGLE [OUTDOOR UNIT : INDOOR UNIT = 1 : 1]

Type	HP	Capacity				
		Hyper Inverter				
		1.5	2.0	2.5	3.0	4.0
		4.0	5.0	6.0	7.1	10.0
		Btu/h	13,700	17,100	19,100	23,900
kcal/h	3,440	4,300	4,816	6,020	8,600	
4way FDT  CEILING CASSETTE	Indoor unit					
		FDT40VD	FDT50VD	FDT60VD	FDT71VD	FDT100VD
	Outdoor unit					
	1phase	SRC40ZIX-S	SRC50ZIX-S	SRC60ZIX-S	FDC71VNX	FDC100VNX
	3phase					FDC100VSX
	Set 1phase	FDT40ZIXVD	FDT50ZIXVD	FDT60ZIXVD	FDT71VNXVD	FDT100VNXVD
	3phase					FDT100VSXVD
	Indoor unit					
		FDTC40VD	FDTC50VD	FDTC60VD		
	Outdoor unit					
1phase	SRC40ZIX-S	SRC50ZIX-S	SRC60ZIX-S			
Set 1phase	FDTC40ZIXVD	FDTC50ZIXVD	FDTC60ZIXVD			
High Static pressure FDU  DUCT CONNECTED	Indoor unit					
					FDU71VD	FDU100VD
	Outdoor unit					
	1phase				FDC71VNX	FDC100VNX
	3phase					FDC100VSX
	Set 1phase				*FDU71VNXVD	*FDU100VNXVD
	3phase					*FDU100VSXVD
	Indoor unit					
			FDUM50VD	FDUM60VD	FDUM71VD	FDUM100VD
	Outdoor unit					
1phase		SRC50ZIX-S	SRC60ZIX-S	FDC71VNX	FDC100VNX	
3phase					FDC100VSX	
Set 1phase		FDUM50ZIXVD	FDUM60ZIXVD	FDUM71VNXVD	FDUM100VNXVD	
3phase					FDUM100VSXVD	
FDEN  CEILING SUSPENDED	Indoor unit					
		FDEN40VD	FDEN50VD	FDEN60VD	FDEN71VD	FDEN100VD
	Outdoor unit					
	1phase	SRC40ZIX-S	SRC50ZIX-S	SRC60ZIX-S	FDC71VNX	FDC100VNX
	3phase					FDC100VSX
	Set 1phase	FDEN40ZIXVD	FDEN50ZIXVD	FDEN60ZIXVD	FDEN71VNXVD	FDEN100VNXVD
	3phase					FDEN100VSXVD

Range (Rated Cooling Capacity)

		<i>Micro Inverter</i>						
5.0	6.0	4.0	5.0	6.0	8.0	10.0		
12.5	14.0	10.0	12.5	14.0	20.0	25.0		
42,700	47,800	34,100	42,700	47,800	68,300	85,400		
10,750	12,040	8,600	10,750	12,040	17,200	21,500		
								
FDT125VD	FDT140VD	FDT100VD	FDT125VD	FDT140VD				
 NEW								
FDC125VNX	FDC140VNX	FDC100VN	FDC125VN	FDC140VN				
FDC125VSX	FDC140VSX	FDC100VS	FDC125VS	FDC140VS				
FDT125VNXVD	FDT140VNXVD	FDT100VNVD	FDT125VNVD	FDT140VNVD				
FDT125VSXVD	FDT140VSXVD	FDT100VSVD	FDT125VSVD	FDT140VSVD				
								
FDU125VD	FDU140VD	FDU100VD	FDU125VD	FDU140VD	FDU200VD	FDU250VD		
 NEW								
FDC125VNX	FDC140VNX	FDC100VN	FDC125VN	FDC140VN				
FDC125VSX	FDC140VSX	FDC100VS	FDC125VS	FDC140VS	FDC200VS	FDC250VS		
*FDU125VNXVD	*FDU140VNXVD	*FDU100VNVD	*FDU125VNVD	*FDU140VNVD				
*FDU125VSXVD	*FDU140VSXVD	*FDU100VSVD	*FDU125VSVD	*FDU140VSVD	FDU200VSVD	FDU250VSVD		
								
FDUM125VD	FDUM140VD	FDUM100VD	FDUM125VD	FDUM140VD				
 NEW								
FDC125VNX	FDC140VNX	FDC100VN	FDC125VN	FDC140VN				
FDC125VSX	FDC140VSX	FDC100VS	FDC125VS	FDC140VS				
FDUM125VNXVD	FDUM140VNXVD	FDUM100VNVD	FDUM125VNVD	FDUM140VNVD				
FDUM125VSXVD	FDUM140VSXVD	FDUM100VSVD	FDUM125VSVD	FDUM140VSVD				
								
FDEN125VD	FDEN140VD	FDEN100VD	FDEN125VD	FDEN140VD				
 NEW								
FDC125VNX	FDC140VNX	FDC100VN	FDC125VN	FDC140VN				
FDC125VSX	FDC140VSX	FDC100VS	FDC125VS	FDC140VS				
FDEN125VNXVD	FDEN140VSXVD	FDEN100VNVD	FDEN125VNVD	FDEN140VNVD				
FDEN125VSXVD	FDEN140VSXVD	FDEN100VSVD	FDEN125VSVD	FDEN140VSVD				

*Not available in 60Hz

CEILING CASSETTE -4way-

FDT



FDT 40/50/60/71/
100/125/140VD



Wired remote control

Wireless remote control



RC-E4
(Option)

RCH-E3
(Option)

RCN-T-36W-E
(Option)

Point 1 Arrangement of installation balance of indoor unit

Checking from access ports with detachable covers at each corner, arrangement of installation balance of indoor unit can be available without removing a panel. Workability is improved and time of installation is reduced.



Point 2 Installation Workability

For wireless control simply insert the infrared receiver kit on a corner of the panel



wireless remote control
RCN-T-36W-E

Point 3 Easy checking of drain pan

Easy checking of drain pan condition is available by removing corner lid only. Due to new design changing fan motor is available without removing a panel. Temporally setting of drain pan is also available.

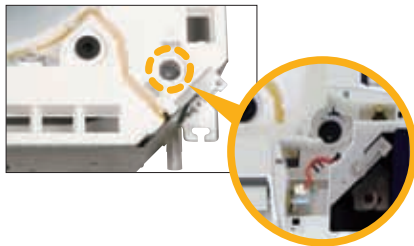

Point 4 700mm Drain Pump

Drain can be discharged upwards by 700mm from the ceiling surface. It allows a piping layout with a high degree of freedom. Depending on the installation location and 260mm flexible hose as a standard equipment supports easy workability.

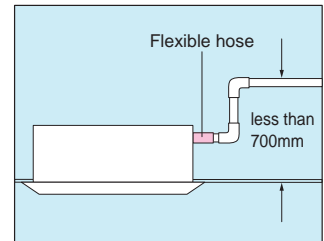

Outline drawing (Unit:mm)

Model FDT40,50,60,71VD

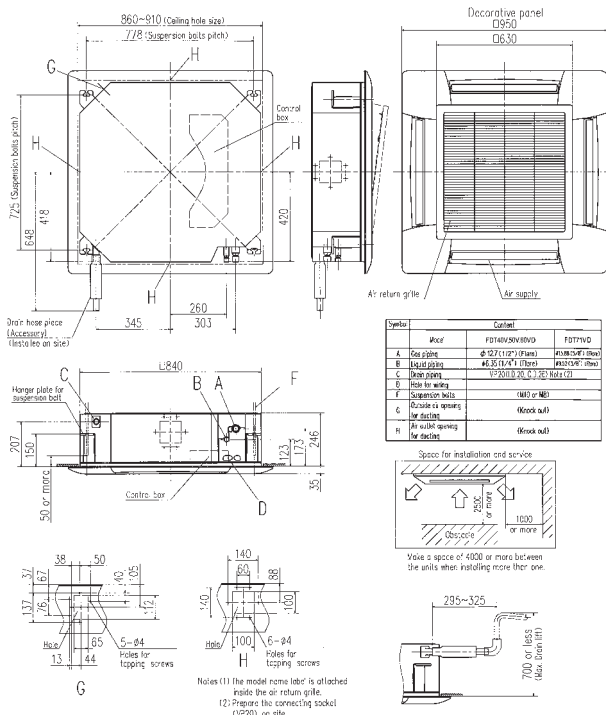

Model 100,125,140VD

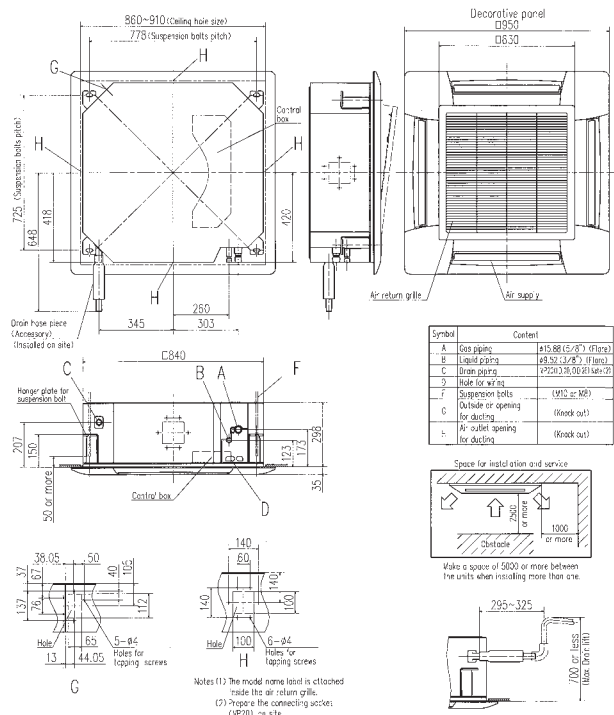

SPECIFICATIONS

			Hyper Inverter				
Set model name			FDT40ZIXVD	FDT50ZIXVD	FDT60ZIXVD	FDT71VNXVD	FDT100VNXVD
Indoor name			FDT40VD	FDT50VD	FDT60VD	FDT71VD	FDT100VD
Outdoor name			SRC40ZIX-S	SRC50ZIX-S	SRC60ZIX-S	FDC71VNX	FDC100VNX
Power source			1Phase 220-240V 50Hz, 1Phase 220V 60Hz				
Nominal cooling capacity (Min~Max)	ISO-T1(JIS)	kW	4.0 (1.8~4.7)	5.0 (2.2~5.6)	5.6 (2.8~6.3)	7.1 (3.2~8.0)	10.0 (4.0~11.2)
Nominal heating capacity (Min~Max)	ISO-T1(JIS)	kW	4.5 (2.0~5.4)	5.4 (2.5~6.3)	6.7 (3.1~7.1)	8.0 (3.6~9.0)	11.2 (4.0~12.5)
Power Consumption	Cooling/Heating	kW	0.93/1.15	1.29/1.29	1.57/1.85	1.90/2.07	2.50/2.58
COP	Cooling/Heating		4.30/3.91	3.88/4.19	3.57/3.62	3.74/3.86	4.00/4.34
Energy label	Cooling/Heating		A/A	A/A	A/A	A/A	A/A
Inrush current (Max. running current)		A	5(12)	5(14)		5(17)	5(24)
Sound level *1 ※	Indoor	dB(A)	Hi:33 Me:31 Lo:30			Hi:35 Me:33 Lo:31	Hi:40 Me:37 Lo:35
	Outdoor		47	48	Cooling:51 Heating:48	Cooling:48 Heating:50	
Air flow ※	Indoor	CMM	Hi:18 Me:16 Lo:14		Hi:18 Me:16 Lo:14	Hi:21 Me:19 Lo:17	Hi:27 Me:24 Lo:20
	Outdoor		40	Cooling:60 Heating:50		100	
Exterior dimensions	Height x Width x Depth	mm	Unit:246x840x840 Panel:35x950x950				Unit:298x840x840 Panel:35x950x950
Net weight	Unit+Panel	kg	27.5(Unit:22 Panel:5.5)		29.5(Unit:24 Panel:5.5)		32.5(Unit:27 Panel:5.5)
Panel			T-PSA-3AW-E				
Air filter, Q'ty			Pocket Plastic net x1 (Washable)				
Remote control(option)			Wired:RC-E4, RCH-E3 Wireless:RCN-T-36W-E				
Exterior dimensions	Height x Width x Depth	mm	640x800(+71)x290		750x880(+88)x340	1,300x970x370	
Net weight		kg	43		60	105	
Type of compressor			Scroll		Rotary		
Ref.amount precharged		kg(m)	1.4(15)		2.95(30)	4.5(30)	
Ref.piping size	Liquid/Gas	ø	6.35/12.7		9.52/15.88		
Range of usage	Ref.piping length	m	30		50	100	
	Vertical height difference	O/U is higher	20		30	30	
	O/U is lower	20		15	15		
Operating temperature range	Cooling	O/U	-15~43*2				
	Heating	O/U	-15~20		-20~20		

SPECIFICATIONS

			Hyper Inverter				
Set model name			FDT125VNXVD	FDT140VNXVD	FDT100VSXVD	FDT125VSXVD	FDT140VSXVD
Indoor name			FDT125VD	FDT140VD	FDT100VD	FDT125VD	FDT140VD
Outdoor name			FDC125VNX	FDC140VNX	FDC100VSX	FDC125VSX	FDC140VSX
Power source			1Phase 220-240V 50Hz, 1Phase 220V 60Hz		3Phase 380-415V 50Hz, 3Phase 380V 60Hz		
Nominal cooling capacity (Min~Max)	ISO-T1(JIS)	kW	12.5 (5.0~14.0)	14.0 (5.0~16.0)	10.0 (4.0~11.2)	12.5 (5.0~14.0)	14.0 (5.0~16.0)
Nominal heating capacity (Min~Max)	ISO-T1(JIS)	kW	14.0 (4.0~17.0)	16.0 (4.0~18.0)	11.2 (4.0~16.0)	14.0 (4.0~18.0)	16.0 (4.0~20.0)
Power Consumption	Cooling/Heating	kW	3.28/3.43	4.19/4.20	2.50/2.58	3.28/3.43	4.19/4.20
COP	Cooling/Heating		3.81/4.08	3.34/3.81	4.00/4.34	3.81/4.08	3.34/3.81
Energy label	Cooling/Heating		A/A	A/A	A/A	A/A	A/A
Inrush current (Max. running current)		A	5(26)		5(15)		
Sound level *1 ※	Indoor	dB(A)	Hi:42 Me:40 Lo:37	Hi:43 Me:41 Lo:38	Hi:40 Me:37 Lo:35	Hi:42 Me:40 Lo:37	Hi:43 Me:41 Lo:38
	Outdoor		Cooling:48 Heating:50	Cooling:49 Heating:52	Cooling:48 Heating:50	Cooling:49 Heating:52	
Air flow ※	Indoor	CMM	Hi:30 Me:27 Lo:23		Hi:27 Me:24 Lo:20	Hi:30 Me:27 Lo:23	
	Outdoor		100				
Exterior dimensions	Height x Width x Depth	mm	Unit:298x840x840 Panel:35x950x950				
Net weight	Unit+Panel	kg	32.5(Unit:27 Panel:5.5)				
Panel			T-PSA-3AW-E				
Air filter, Q'ty			Pocket Plastic net x1 (Washable)				
Remote control(option)			Wired:RC-E4, RCH-E3 Wireless:RCN-T-36W-E				
Exterior dimensions	Height x Width x Depth	mm	1,300x970x370				
Net weight		kg	105				
Type of compressor			Rotary				
Ref.amount precharged		kg(m)	4.5(30)				
Ref.piping size	Liquid/Gas	ø	9.52/15.88				
Range of usage	Ref.piping length	m	100				
	Vertical height difference	O/U is higher	30				
	O/U is lower	15					
Operating temperature range	Cooling	O/U	-15~43*2				
	Heating	O/U	-20~20				

The data are measured under the following conditions(ISO-T1).

Cooling:Indoor temp. of 27°CDB, 19°CWB, and outdoor temp. of 35°CDB. Heating:Indoor temp. of 20°CDB, and outdoor temp. of 7°CDB, 6°CWB.

*1 : Indicates the value in an anechoic chamber. During operation these values are somewhat higher due to ambient conditions.

*2 : If a cooling operation is conducted when the outdoor air temperature is -5°C or lower, the outdoor unit should be installed at a place where it is not influenced by natural wind. If wind blows, the low pressure will drop and compressor frequency will increase, this will cause the capacity to drop and may cause the unit to break down.

※ Powerful-Hi can be selected. Sound level: 40/50ZIXVD 39dB, 60ZIXVD 46dB, 71VNXVD 46dB, 100/125/140VNXVD 51dB, 100/125/140VSXVD 51dB
Air flow: 40/50ZIXVD 20CMM, 60ZIXVD 28CMM, 71VNXVD 28CMM, 100/125/140VNXVD 37CMM, 100/125/140VSXVD 37CMM

CEILING CASSETTE -4way Compact (600 X 600mm)-

FDTC



Fits into standard 600 x 600 ceiling



FDTC 40/50/60VD

Wired remote control



RC-E4
(Option)



RCH-E3
(Option)

Wireless remote control



RCN-TC-24W-ER
(Option)



Point 1 Quiet operation

(Sound level in the Lo mode)

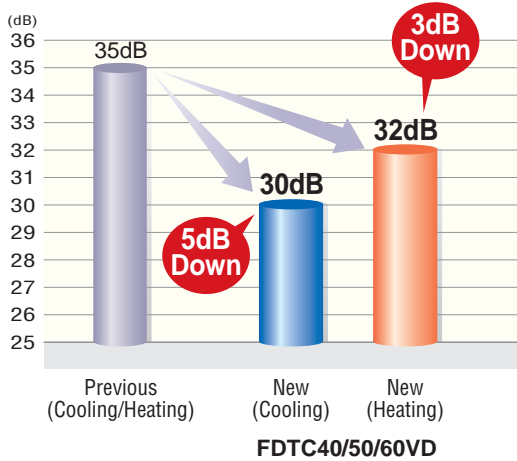

Point 2 "CLEARER" Air Flow

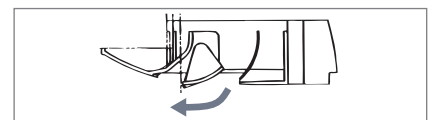
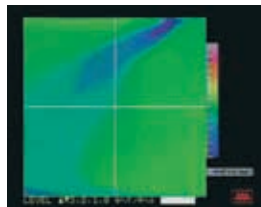

New shape & angled louver redirects the air current away from the ceiling, to reduce ceiling stains

Point 3 Installation Workability



For wireless control simply insert the infrared receiver kit on a corner of the panel



wireless remote control
RCN-TC-24W-ER

Point 4 Compact Concept

The industry's lowest level 248mm height.

Panel size (700x700) is suitable for 600x600 ceiling panel. All indoor unit size is (WxD: 570x570). It brings easy installation for 600x600 ceiling panel.

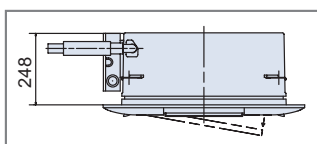

Ultra slim design at just 248mm above the ceiling

Point 5 Comfortable and Convenient

- All units are 18.5kg, light weight unit.
- Thanks to width and depth of exterior dimensions of a indoor unit are 570mm each, the installation work can be conducted smoothly with a beautiful finishing in 2x2 ceiling size.
- **600mm Drain Pump is mounted.** Drain can be discharged upward by 600 mm from the ceiling surface close to the indoor unit. It allows a piping layout with a high degree of freedom depending on the installation location.

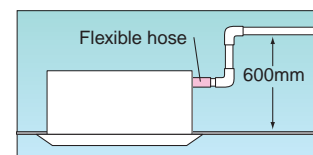

Outline drawing (Unit:mm)

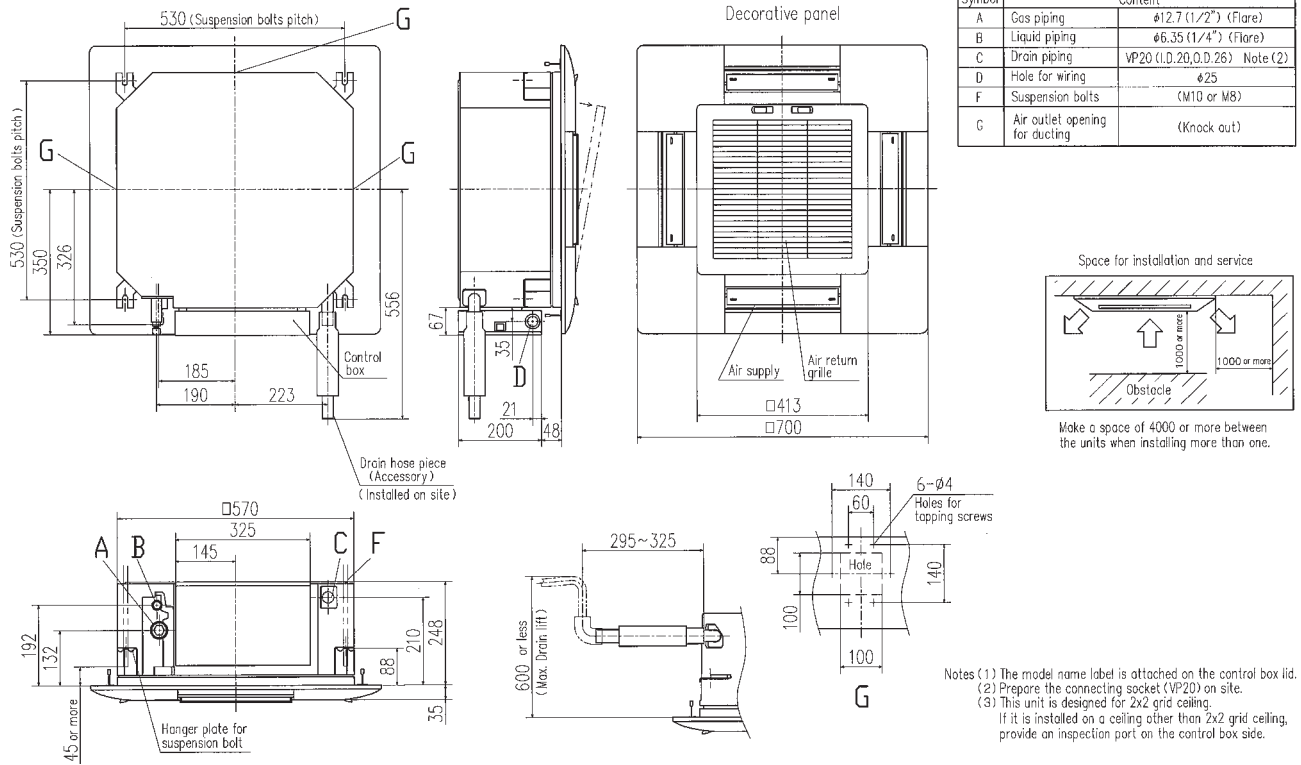

SPECIFICATIONS

			Hyper Inverter			
Set model name			FDTC40ZIXVD	FDTC50ZIXVD	FDTC60ZIXVD	
Indoor name			FDTC40VD			
Outdoor name			SRC40ZIX-S			
Power source			1Phase 220-240V 50Hz, 1Phase 220V 60Hz			
Nominal cooling capacity (Min~Max)	ISO-T1(JIS)	kW	4.0 (1.8~4.7)			
Nominal heating capacity (Min~Max)	ISO-T1(JIS)	kW	4.5 (2.0~5.4)			
Power Consumption	Cooling/Heating	kW	1.04/1.10			
COP	Cooling/Heating		3.85/4.09			
Energy label	Cooling/Heating		A/A			
Inrush current (Max. running current)	A		5(12)			
Sound level *1 ※	Indoor	dB(A)	Cooling : Hi:42 Me:36 Lo:30		Cooling : Hi:46 Me:39 Lo:30	
	Outdoor		Heating : Hi:42 Me:36 Lo:32		Heating : Hi:46 Me:39 Lo:32	
Air flow ※	Indoor	CMM	Cooling : Hi:11.5 Me:9 Lo:7		Cooling : Hi:13.5 Me:10 Lo:7	
	Outdoor		Heating : Hi:11.5 Me:9 Lo:8		Heating : Hi:13.5 Me:10 Lo:8	
Exterior dimensions	Height x Width x Depth	mm	Unit:248x570x570 Panel:35x700x700			
Net weight	Unit+Panel	kg	18.5(Unit:15 Panel:3.5)			
Panel			TC-PSA-25W-E			
Air filter, Q'ty			Pocket Plastic net x1 (Washable)			
Remote control(option)			Wired:RC-E4, RCH-E3 Wireless:RCN-TC-24W-ER			
Exterior dimensions	Height x Width x Depth	mm	640x800(+71)x290			
Net weight		kg	43			
Type of compressor			Scroll			
Ref.amount precharged		kg(m)	1.4(15)			
Ref.piping size	Liquid/Gas	ø	6.35/12.7			
Range of usage	Ref.piping length	m	30			
	Vertical height difference	O/U is higher	m	20		
		O/U is lower	m	20		
Operating temperature range	Cooling	O/U	-15~43*2			
	Heating	O/U	-15~20			

The data are measured under the following conditions(ISO-T1).

Cooling:Indoor temp. of 27°CDB, 19°CWB, and outdoor temp. of 35°CDB. Heating:Indoor temp. of 20°CDB, and outdoor temp. of 7°CDB, 6°CWB.

*1 : Indicates the value in an anechoic chamber. During operation these values are somewhat higher due to ambient conditions.

*2 : If a cooling operation is conducted when the outdoor air temperature is -5°C or lower, the outdoor unit should be installed at a place where it is not influenced by natural wind. If wind blows, the low pressure will drop and compressor frequency will increase, this will cause the capacity to drop and may cause the unit to break down.

※ Powerful-Hi can be selected. Sound level: 40/50/60ZIXVD 47dB Air flow: 40/50/60ZIXVD 13.5CMM

DUCT CONNECTED -High Static pressure-

FDU



RC-E4 (Option)



RCN-KIT3-E (Option)



FDU 71/100/125/140VD



FDU 200/250VD

Fan control kit (100-200Pa)



U-FCRA (For 200/250VD) (option)

Point 1 Enhanced installation workability

Quiet, Lightweight and Compact

With the FDU71, the noise level is only 37dB (low), weight is only 40kg and height is only 297mm. In addition 600mm Drain Pump is mounted in FDU71/100/125/140VD. The indoor unit is completely hidden in the ceiling, so this is suitable for spaces with classy interior decoration.

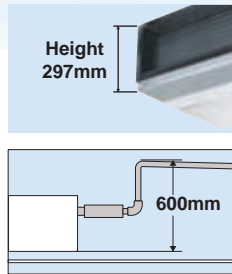

Point 2 Adaptability to higher static pressures

High static pressure of 200 Pa (FDU200/250VD) extends the degree of freedom in the designing of air conditioners.

This is a real and earnest model for duct air-conditioning. A unit external static pressure of up to 200 Pa (FDU200/250VD) is possible. Precise air flow designing is possible.

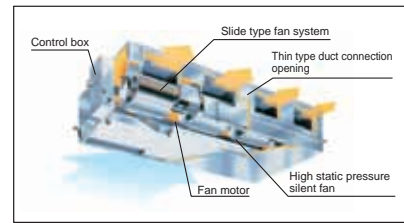

Outline drawing (Unit:mm)

FDU71VD

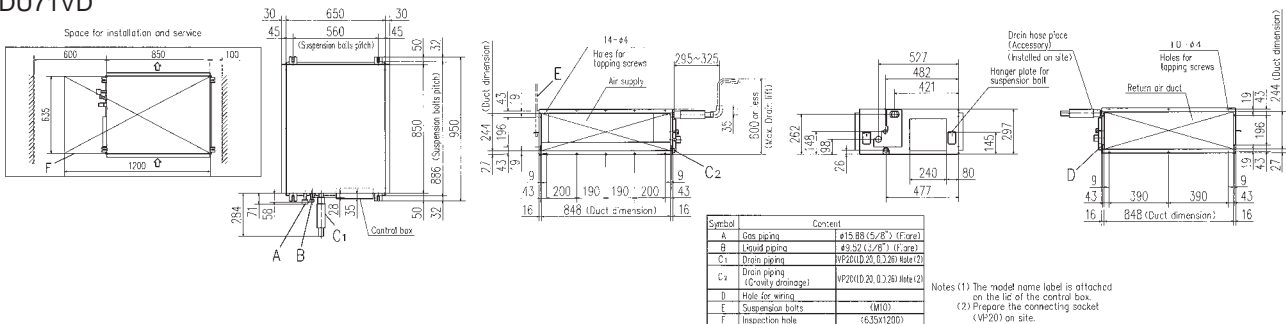

FDU100,125,140VD

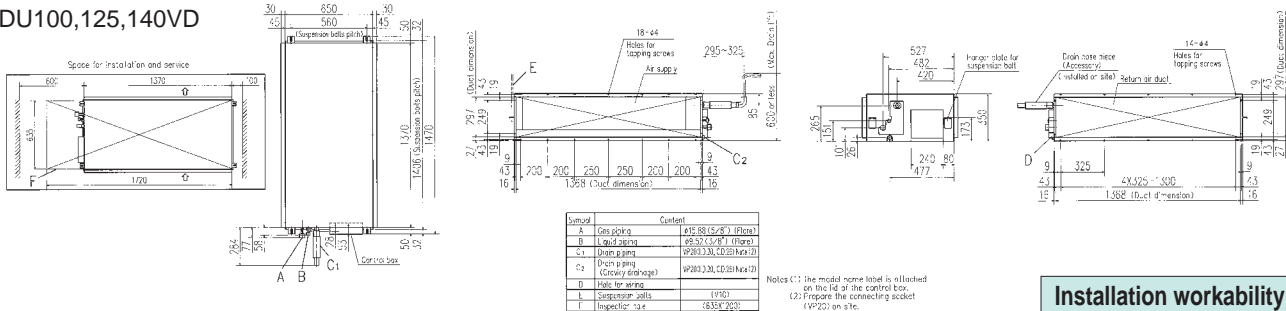

FDU200,250VD

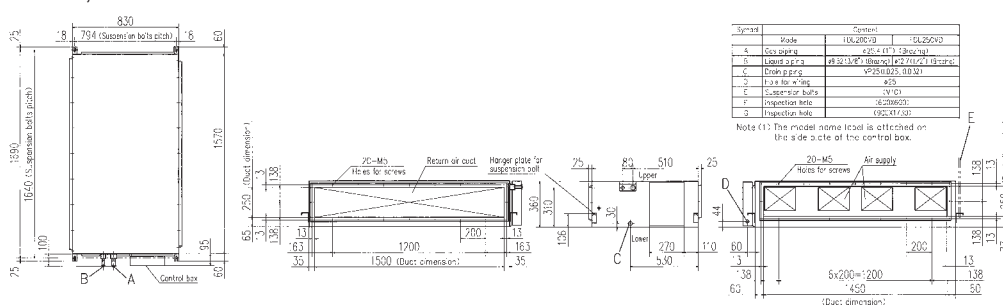

Installation workability (FDU200,250VD)

Using piping attachment that has flared connection and brazed connection ends, there is no need conduct brazing work inside the outdoor unit.

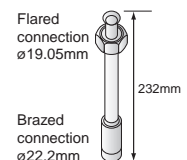

SPECIFICATIONS

*Not available in 60Hz

		<i>Hyper Inverter</i>					
Set model name		*FDU171VNXVD	*FDU100VNXVD	*FDU125VNXVD	*FDU140VNXVD		
Indoor name		FDU171VD	FDU100VD	FDU125VD	FDU140VD		
Outdoor name		FDC171VNX	FDC100VNX	FDC125VNX	FDC140VNX		
Power source		1Phase 220-240V 50Hz					
Nominal cooling capacity (Min~Max)	ISO-T1(JIS)	kW	7.1 (3.2~8.0)	10.0 (4.0~11.2)	12.5 (5.0~14.0)	14.0 (5.0~16.0)	
Nominal heating capacity (Min~Max)	ISO-T1(JIS)	kW	8.0 (3.6~9.0)	11.2 (4.0~12.5)	14.0 (4.0~17.0)	16.0 (4.0~18.0)	
Power Consumption	Cooling/Heating	kW	2.15/2.15	2.78/2.90	3.44/3.67	4.20/4.30	
COP	Cooling/Heating		3.30/3.72	3.60/3.86	3.63/3.81	3.33/3.72	
Energy label	Cooling/Heating		A/A	A/A	A/A	A/A	
Inrush current (Max. running current)		A	5(17)	5(25)	5(29)	5(30)	
Sound level*1	Indoor	dB(A)	Hi:41 Lo:37		Hi:42 Lo:37		
	Outdoor		Cooling:51 Heating:48	Cooling:48 Heating:50	Hi:43 Lo:38		
Air flow	Indoor	CMM	Hi:20 Lo:17		Hi:34 Lo:27		
	Outdoor		Cooling:60 Heating:50	100			
External static pressure		Pa	Standard:50, Max:130				
Indoor unit	Exterior dimensions	Height x Width x Depth	mm 297x850x650		350x1,370x650		
	Net weight	kg	40		63		
	Air filter, Q'ty		Procure locally				
	Remote control(option)		Wired:RC-E4, RCH-E3 Wireless:RCN-KIT3-E				
Outdoor unit	Exterior dimensions	Height x Width x Depth	mm 750x880(+88)x340		1,300x970x370		
	Net weight	kg	60		105		
	Type of compressor		Rotary				
	Ref.amount precharged	kg(m)	2.95(30)		4.5(30)		
Range of usage	Ref.piping size	Liquid/Gas	ø		9.52/15.88		
	Ref.piping length	m	50		100		
	Vertical height difference	O/U is higher	m	30			
		O/U is lower	m	15			
Operating temperature range	Cooling	O/U	-15~43*2				
	Heating	O/U	-20~20				

SPECIFICATIONS

*Not available in 60Hz

		<i>Hyper Inverter</i>					
Set model name		*FDU100VSXVD	*FDU125VSXVD	*FDU140VSXVD			
Indoor name		FDU100VD	FDU125VD	FDU140VD			
Outdoor name		FDC100VSX	FDC125VSX	FDC140VSX			
Power source		3Phase 380-415V 50Hz					
Nominal cooling capacity (Min~Max)	ISO-T1(JIS)	kW	10.0 (4.0~11.2)	12.5 (5.0~14.0)	14.0 (5.0~16.0)		
Nominal heating capacity (Min~Max)	ISO-T1(JIS)	kW	11.2 (4.0~16.0)	14.0 (4.0~18.0)	16.0 (4.0~20.0)		
Power Consumption	Cooling/Heating	kW	2.78/2.90	3.44/3.67	4.20/4.30		
COP	Cooling/Heating		3.60/3.86	3.63/3.81	3.33/3.72		
Energy label	Cooling/Heating		A/A	A/A	A/A		
Inrush current (Max. running current)		A	5(16)	5(18)	5(19)		
Sound level*1	Indoor	dB(A)	Hi:42 Lo:37		Hi:43 Lo:38		
	Outdoor		Cooling:48 Heating:50	Cooling:48 Heating:50	Cooling:49 Heating:52		
Air flow	Indoor	CMM	Hi:34 Lo:27		Hi:42 Lo:33.5		
	Outdoor		100				
External static pressure		Pa	Standard:50, Max:130				
Indoor unit	Exterior dimensions	Height x Width x Depth	mm		350x1,370x650		
	Net weight	kg	63		63		
	Air filter, Q'ty		Procure locally				
	Remote control(option)		Wired:RC-E4, RCH-E3 Wireless:RCN-KIT3-E				
Outdoor unit	Exterior dimensions	Height x Width x Depth	mm		1,300x970x370		
	Net weight	kg	105		105		
	Type of compressor		Rotary				
	Ref.amount precharged	kg(m)	4.5(30)		4.5(30)		
Range of usage	Ref.piping size	Liquid/Gas	ø		9.52/15.88		
	Ref.piping length	m	100		100		
	Vertical height difference	O/U is higher	m	30			
		O/U is lower	m	15			
Operating temperature range	Cooling	O/U	-15~43*2				
	Heating	O/U	-20~20				

The data are measured under the following conditions(ISO-T1).

Cooling:Indoor temp. of 27°CDB, 19°CWB, and outdoor temp. of 35°CDB. Heating:Indoor temp. of 20°CDB, and outdoor temp. of 7°CDB, 6°CWB. External static pressure of FDU171/100/125/140 is 60Pa and that of FDU200/250 is 100Pa.

*1 : Indicates the value in an anechoic chamber. During operation these values are somewhat higher due to ambient conditions.

*2 : External static pressure is changeable to be set by the remote control. Standard external static pressure is factory setting. MAX external static pressure is "High static pressure" setting. The values of sound pressure level become 5dB(A) higher at external static pressure of 130Pa.

*3 : If a cooling operation is conducted when the outdoor air temperature is -5°C or lower, the outdoor unit should be installed at a place where it is not influenced by natural wind. If wind blows, the low pressure will drop and compressor frequency will increase, this will cause the capacity to drop and may cause the unit to break down.

DUCT CONNECTED -Middle Static pressure-

FDUM



Wired remote control



RC-E4 (Option)



RCH-E3 (Option)

Wireless remote control



RCN-KIT3-E (Option)

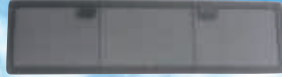

Filter kit

UM-FL1E : for 50

UM-FL2E : for 60, 71

UM-FL3E : for 100, 125, 140 (option)

external static pressure loss:5pa



FDUM 50/60/71/

100/125/140VD

Point 1

Various Adaptability

Selectable static pressure and Flexible duct design with selectable air suction (direct suction /duct suction) can meet wide pattern of installation.

model	Static pressure Pa (50Hz)	
	Standard	Max
50/60/71VD	50	85
100VD	60	90
125/140VD	60	85

Point 2

600mm Drain Pump

Drain can be discharged upwards by 600mm from the ceiling surface. It allows a piping layout with a high degree of freedom Depending on the installation location.

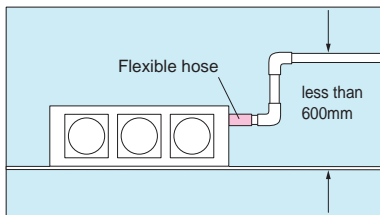

Outline drawing (Unit:mm)

Model FDUM50VD

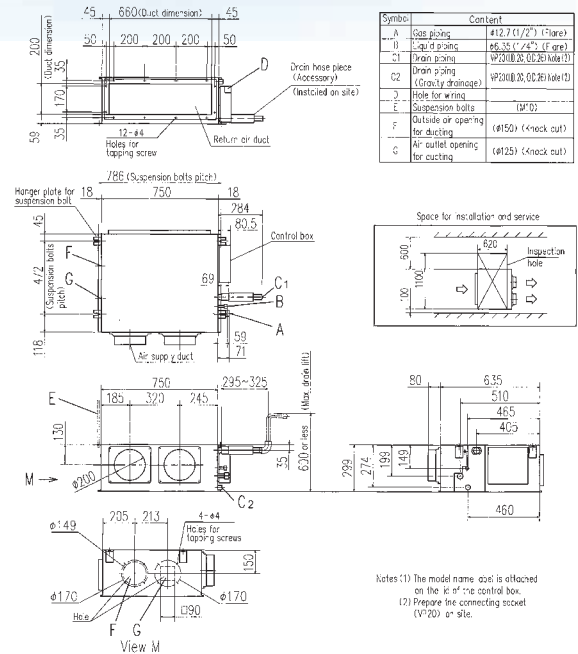

Models FDUM60V,71VD

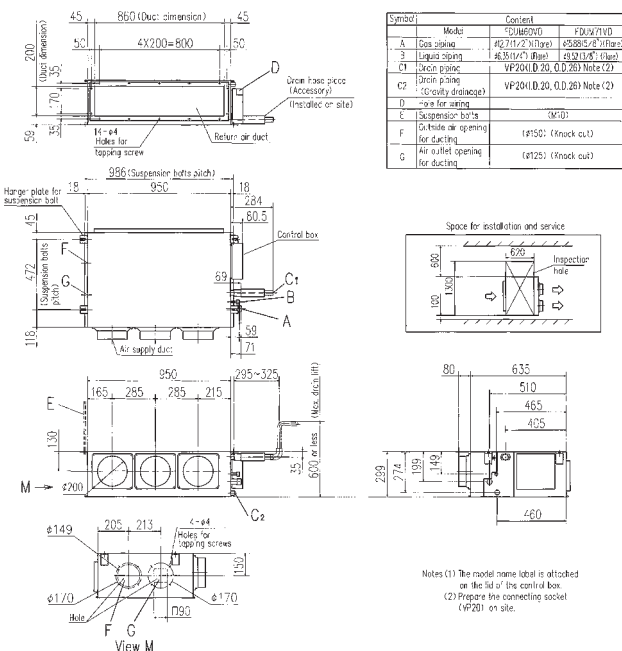

Models FDUM100V,125V,140VD

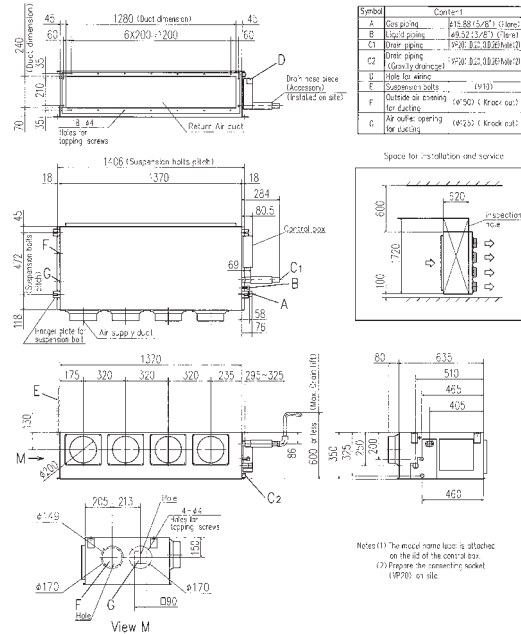

SPECIFICATIONS

			Hyper Inverter				
Set model name			FDUM50ZIXVD	FDUM60ZIXVD	FDUM71VNVVD	FDUM100VNXVD	
Indoor name			FDUM50VD	FDUM60VD	FDUM71VD	FDUM100VD	
Outdoor name			SRC50ZIX-S	SRC60ZIX-S	FDC71VNX	FDC100VNX	
Power source			1Phase 220-240V 50Hz, 1Phase 220V 60Hz				
Nominal cooling capacity (Min~Max)	ISO-T1(JIS)	kW	5.0 (2.2~5.6)	5.6 (2.8~6.3)	7.1 (3.2~8.0)	10.0 (4.0~11.2)	
Nominal heating capacity (Min~Max)	ISO-T1(JIS)	kW	5.4 (2.5~6.3)	6.7 (3.1~7.1)	8.0 (3.6~9.0)	11.2 (4.0~12.5)	
Power Consumption	Cooling/Heating	kW	1.52/1.41	1.86/1.96	2.14/2.16	2.72/2.95	
COP	Cooling/Heating		3.29/3.83	3.01/3.42	3.32/3.70	3.68/3.80	
Energy label	Cooling/Heating		A/A	B/B	A/A	A/A	
Inrush current (Max. running current)	A		5(14)				
Sound level *1 ※	Indoor	dB(A)	Hi:34 Me:31 Lo:28			Hi:35 Me:32 Lo:29	Hi:37 Me:35 Lo:32
	Outdoor		47	48	Cooling:51 Heating:48	Cooling:48 Heating:50	
Air flow ※	Indoor	CMM	Hi:13 Me:12 Lo:11	Hi:16 Me:15 Lo:14	Hi:20 Me:18 Lo:15	Hi:28 Me:25 Lo:22	
	Outdoor		40		Cooling:60 Heating:50	100	
Static pressure	50Hz/60Hz	Pa	Standard:50/40, Max:85/90		Standard:60/60, Max:90/100		
Indoor unit	Exterior dimensions	Height x Width x Depth	299x750x635		299x950x635		
	Net weight	kg	34		40		
	Air filter, Q'ty		Procure locally				
	Remote control(option)		Wired:RC-E4, RCH-E3 Wireless:RCN-KIT3-E				
Outdoor unit	Exterior dimensions	Height x Width x Depth	640x800(+71)x290		750x880(+88)x340		
	Net weight	kg	43		60		
	Type of compressor		Scroll		Rotary		
	Ref.amount precharged	kg(m)	1.4(15)		2.95(30)		
Range of usage	Ref.piping size	Liquid/Gas	ø 6.35/12.7		9.52/15.88		
	Ref.piping length	m	30		50		
	Vertical height difference	O/U is higher	m 20		30		
		O/U is lower	m 20		15		
Operating temperature range	Cooling	O/U	-15~43*2				
	Heating	O/U	-15~20			-20~20	

SPECIFICATIONS

			Hyper Inverter					
Set model name			FDUM125VNXVD	FDUM140VNXVD	FDUM100VSXVD	FDUM125VSXVD	FDUM140VSXVD	
Indoor name			FDUM125VD	FDUM140VD	FDUM100VD	FDUM125VD	FDUM140VD	
Outdoor name			FDC125VNX	FDC140VNX	FDC100VSX	FDC125VSX	FDC140VSX	
Power source			1Phase 220-240V 50Hz, 1Phase 220V 60Hz			3Phase 380-415V 50Hz, 3Phase 380V 60Hz		
Nominal cooling capacity (Min~Max)	ISO-T1(JIS)	kW	12.5 (5.0~14.0)	14.0 (5.0~16.0)	10.0 (4.0~11.2)	12.5 (5.0~14.0)	14.0 (5.0~16.0)	
Nominal heating capacity (Min~Max)	ISO-T1(JIS)	kW	14.0 (4.0~17.0)	16.0 (4.0~18.0)	11.2 (4.0~16.0)	14.0 (4.0~18.0)	16.0 (4.0~20.0)	
Power Consumption	Cooling/Heating	kW	3.62/3.77	4.34/4.69	2.72/2.95	3.62/3.77	4.34/4.69	
COP	Cooling/Heating		3.45/3.71	3.23/3.41	3.68/3.80	3.45/3.71	3.23/3.41	
Energy label	Cooling/Heating		A/A	A/B	A/A	A/A	A/B	
Inrush current (Max. running current)	A		5(26)			5(15)		
Sound level *1 ※	Indoor	dB(A)	Hi:38 Me:36 Lo:33			Hi:37 Me:35 Lo:32	Hi:38 Me:36 Lo:33	
	Outdoor		Cooling:48 Heating:50	Cooling:49 Heating:52	Cooling:48 Heating:50	Cooling:49 Heating:52		
Air flow ※	Indoor	CMM	Hi:28 Me:25 Lo:22					
	Outdoor		100					
Static pressure	50Hz/60Hz	Pa	Standard:60/55, Max:85/100		Standard:60/60, Max:90/100	Standard:60/55, Max:85/100		
Indoor unit	Exterior dimensions	Height x Width x Depth	350x1,370x635					
	Net weight	kg	59					
	Air filter, Q'ty		Procure locally					
	Remote control(option)		Wired:RC-E4, RCH-E3 Wireless:RCN-KIT3-E					
Outdoor unit	Exterior dimensions	Height x Width x Depth	1,300x970x370					
	Net weight	kg	105					
	Type of compressor		Rotary					
	Ref.amount precharged	kg(m)	4.5(30)					
Range of usage	Ref.piping size	Liquid/Gas	ø 9.52/15.88					
	Ref.piping length	m	100					
	Vertical height difference	O/U is higher	m 30					
		O/U is lower	m 15					
Operating temperature range	Cooling	O/U	-15~43*2					
	Heating	O/U	-20~20					

The data are measured under the following conditions(ISO-T1).

Cooling:Indoor temp. of 27°CDB, 19°CWB, and outdoor temp. of 35°CDB. Heating:Indoor temp. of 20°CDB, and outdoor temp. of 7°CDB, 6°CWB. External static pressure of indoor units is 60Pa.

*1 : Indicates the value in an anechoic chamber. During operation these values are somewhat higher due to ambient conditions.

*2 : If a cooling operation is conducted when the outdoor air temperature is -5°C or lower, the outdoor unit should be installed at a place where it is not influenced by natural wind. If wind blows, the low pressure will drop and compressor frequency will increase, this will cause the capacity to drop and may cause the unit to break down.

※ Powerful-Hi can be selected. Sound level: 50ZIXVD 35dB, 60ZIXVD 38dB, 71VNXVD 38dB, 100/125/140VNXVD 41dB, 100/125/140VSXVD 41dB
Air flow: 50ZIXVD 14CMM, 60ZIXVD 18CMM, 71VNXVD 23CMM, 100/125/140VNXVD 34CMM, 100/125/140VSXVD 34CMM

CEILING SUSPENDED FDEN



FDEN 40/50/60/71/100/125/140VD

Wired remote control



RC-E4
(Option)



RCH-E3
(Option)

Wireless remote control



RCN-E1R
(Option)

Point 1 Improved installation workability Increased freedom of a piping layout

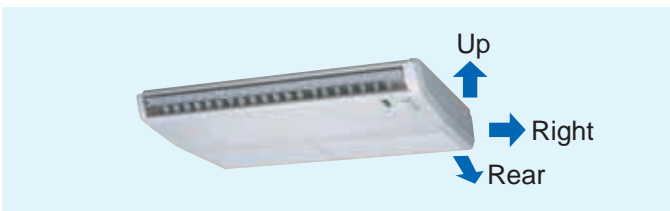

The refrigerant pipe from the unit can be arranged in three directions, rear, right and up. The drain pipe can be arranged in two directions, left and right. This will allow a free layout of piping for various installation conditions. The unit can only be serviced from the bottom.

Point 2 Compact and modern design

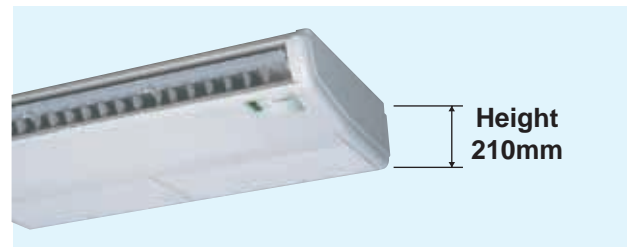

All models fit compactly on ceiling. (Height-210mm or 250mm). Plain, modern design featuring rounded edges gives room a comfortable atmosphere. FDEN40VD, 50VD weights 30kg the lightest level in the industry. Convenient and quick installation.

Outline drawing (Unit:mm)

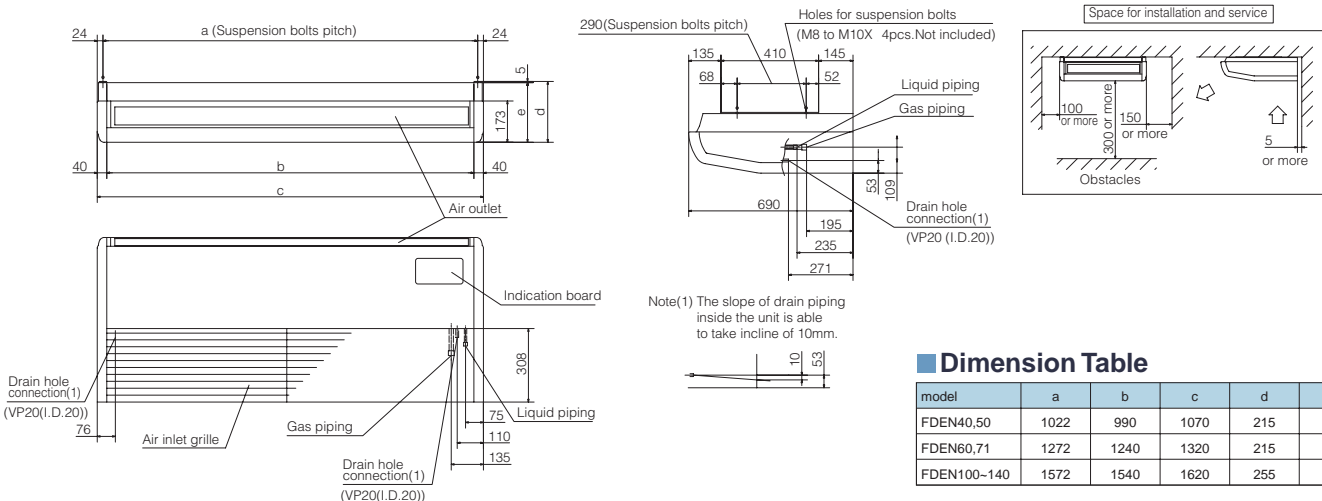

SPECIFICATIONS

			Hyper Inverter					
Set model name			FDEN40ZIXVD	FDEN50ZIXVD	FDEN60ZIXVD	FDEN71VNXVD	FDEN100VNXVD	
Indoor name			FDEN40VD	FDEN50VD	FDEN60VD	FDEN71VD	FDEN100VD	
Outdoor name			SRC40ZIX-S	SRC50ZIX-S	SRC60ZIX-S	FDC71VNX	FDC100VNX	
Power source			1Phase 220-240V 50Hz, 1Phase 220V 60Hz					
Nominal cooling capacity (Min~Max)	ISO-T1(JIS)	kW	4.0 (1.8~4.7)	5.0 (2.2~5.6)	5.6 (2.8~6.3)	7.1 (3.2~8.0)	10.0 (4.0~11.2)	
Nominal heating capacity (Min~Max)	ISO-T1(JIS)	kW	4.5 (2.0~5.4)	5.4 (2.5~6.3)	6.7 (3.1~7.1)	8.0 (3.6~9.0)	11.2 (4.0~12.5)	
Power Consumption	Cooling/Heating	kW	1.04/1.13	1.59/1.58	1.95/2.12	2.11/2.11	2.80/2.88	
COP	Cooling/Heating		3.85/3.98	3.14/3.42	2.87/3.16	3.36/3.79	3.57/3.89	
Energy label	Cooling/Heating		A/A	B/B	C/D	A/A	A/A	
Inrush current (Max. running current)		A	5(12)		5(14)	5(17)	5(24)	
Sound level*1**	Indoor	dB(A)	Hi:39 Me:38 Lo:37			Hi:41 Me:39 Lo:38		Hi:44 Me:41 Lo:39
	Outdoor		47		48	Cooling:51 Heating:48	Cooling:48 Heating:50	
Air flow**	Indoor	CMM	Hi:11 Me:9 Lo:7			Hi:18 Me:14 Lo:12	Hi:18 Me:14 Lo:12	Hi:26 Me:23 Lo:21
	Outdoor		40			Cooling:60 Heating:50	100	
Indoor unit	Exterior dimensions	Height x Width x Depth	210x1,070x690			210x1,320x690		250x1,620x690
	Net weight	kg	28			37		49
	Air filter, Q'ty		Pocket Plastic net x2 (Washable)					
	Remote control(option)		Wired:RC-E4, RCH-E3 Wireless:RCN-E1R					
Outdoor unit	Exterior dimensions	Height x Width x Depth	640x800(+71)x290			750x880(+88)x340		1,300x970x370
	Net weight	kg	43			60		105
	Type of compressor		Scroll					Rotary
	Ref.amount precharged	kg(m)	1.4(15)			2.95(30)		4.5(30)
	Ref.piping size	Liquid/Gas	ø	6.35/12.7			9.52/15.88	
	Ref.piping length	m	30			50		50
	Vertical height difference	O/U is higher	m	20			30	
	O/U is lower	m	20			15		
Operating temperature range	Cooling	O/U	-15~43*2					
	Heating	O/U	-15~20				-20~20	

SPECIFICATIONS

			Hyper Inverter					
Set model name			FDEN125VNXVD	FDEN140VNXVD	FDEN100VSXVD	FDEN125VSXVD	FDEN140VSXVD	
Indoor name			FDEN125VD	FDEN140VD	FDEN100VD	FDEN125VD	FDEN140VD	
Outdoor name			FDC125VNX	FDC140VNX	FDC100VSX	FDC125VSX	FDC140VSX	
Power source			1Phase 220-240V 50Hz, 1Phase 220V 60Hz			3Phase 380-415V 50Hz, 3Phase 380V 60Hz		
Nominal cooling capacity (Min~Max)	ISO-T1(JIS)	kW	12.5 (5.0~14.0)	14.0 (5.0~16.0)	10.0 (4.0~11.2)	12.5 (5.0~14.0)	14.0 (5.0~16.0)	
Nominal heating capacity (Min~Max)	ISO-T1(JIS)	kW	14.0 (4.0~17.0)	16.0 (4.0~18.0)	11.2 (4.0~16.0)	14.0 (4.0~18.0)	16.0 (4.0~20.0)	
Power Consumption	Cooling/Heating	kW	3.86/3.77	4.98/4.69	2.80/2.88	3.86/3.77	4.98/4.69	
COP	Cooling/Heating		3.24/3.71	2.81/3.41	3.57/3.89	3.24/3.71	2.81/3.41	
Energy label	Cooling/Heating		A/A	C/B	A/A	A/A	C/B	
Inrush current (Max. running current)		A	5(26)			5(15)		
Sound level*1**	Indoor	dB(A)	Hi:46 Me:44 Lo:43			Hi:44 Me:41 Lo:39	Hi:46 Me:44 Lo:43	
	Outdoor		Cooling:48 Heating:50	Cooling:49 Heating:52	Cooling:48 Heating:50	Cooling:48 Heating:50	Cooling:49 Heating:52	
Air flow**	Indoor	CMM	Hi:29 Me:26 Lo:23			Hi:26 Me:23 Lo:21	Hi:29 Me:26 Lo:23	
	Outdoor		100					
Indoor unit	Exterior dimensions	Height x Width x Depth	250x1,620x690					
	Net weight	kg	49					
	Air filter, Q'ty		Pocket Plastic net x2 (Washable)					
	Remote control(option)		Wired:RC-E4, RCH-E3 Wireless:RCN-E1R					
Outdoor unit	Exterior dimensions	Height x Width x Depth	1,300x970x370					
	Net weight	kg	105					
	Type of compressor		Rotary					
	Ref.amount precharged	kg(m)	4.5(30)					
	Ref.piping size	Liquid/Gas	ø	9.52/15.88				
	Ref.piping length	m	100			50		100
	Vertical height difference	O/U is higher	m	30			15	
	O/U is lower	m	15					
Operating temperature range	Cooling	O/U	-15~43*2					
	Heating	O/U	-20~20					

The data are measured under the following conditions(ISO-T1).

Cooling:Indoor temp. of 27°CDB, 19°CWB, and outdoor temp. of 35°CDB.

Heating:Indoor temp. of 20°CDB, and outdoor temp. of 7°CDB, 6°CWB.

*1 : Indicates the value in an anechoic chamber. During operation these values are somewhat higher due to ambient conditions.

*2 : If a cooling operation is conducted when the outdoor air temperature is -5°C or lower, the outdoor unit should be installed at a place where it is not influenced by natural wind. If wind blows, the low pressure will drop and compressor frequency will increase, this will cause the capacity to drop and may cause the unit to break down.

** Powerful-Hi can be selected. Sound level: 40/50ZIXVD 46dB, 60ZIXVD 50dB, 71VNXVD 50dB, 100VNXVD 46dB, 125/140VNXVD 50dB, 100VSXVD 46dB, 125/140VSXVD 50dB
Air flow: 40/50ZIXVD 13CMM, 60ZIXVD 22CMM, 71VNXVD 22CMM, 100VNXVD 28CMM, 125/140VNXVD 32CMM, 100VSXVD 28CMM, 125/140VSXVD 32CMM

Micro Inverter [INDOOR UNIT]

CEILING CASSETTE -4way-

FDT



FDT 100/125/140VD

Wired remote control



RC-E4
(Option)



RCH-E3
(Option)

Wireless remote control



RCN-T-36W-E
(Option)

SPECIFICATIONS

		Micro Inverter								
Set model name		FDT100VNVD	FDT125VNVD	FDT140VNVD	FDT100VSVD	FDT125VSVD	FDT140VSVD			
Indoor name		FDT100VD	FDT125VD	FDT140VD	FDT100VD	FDT125VD	FDT140VD			
Outdoor name		FDC100VN	FDC125VN	FDC140VN	FDC100VS	FDC125VS	FDC140VS			
Power source		1Phase 220-240V 50Hz, 1Phase 220V 60Hz			3Phase 380-415V 50Hz, 3Phase 380V 60Hz					
Nominal cooling capacity (Min~Max)	ISO-T1(JIS)	kW	10.0 (4.0~11.2)	12.5 (5.0~14.0)	14.0 (5.0~14.5)	10.0 (4.0~11.2)	12.5 (5.0~14.0)	14.0 (5.0~14.5)		
	ISO-T1(JIS)	kW	11.2 (4.0~12.5)	14.0 (4.0~16.0)	16.0 (4.0~16.5)	11.2 (4.0~12.5)	14.0 (4.0~16.0)	16.0 (4.0~16.5)		
Nominal heating capacity (Min~Max)	ISO-T1(JIS)	kW	11.2 (4.0~12.5)	14.0 (4.0~16.0)	16.0 (4.0~16.5)	11.2 (4.0~12.5)	14.0 (4.0~16.0)	16.0 (4.0~16.5)		
Power Consumption	Cooling/Heating	kW	2.76/2.74	4.05/3.77	4.98/4.57	2.76/2.74	4.05/3.77	4.98/4.57		
COP	Cooling/Heating		3.62/4.09	3.09/3.71	2.81/3.50	3.62/4.09	3.09/3.71	2.81/3.50		
Energy label	Cooling/Heating		A/A	B/A	C/B	A/A	B/A	C/B		
Inrush current (Max. running current)	A		5(24)			5(15)				
Sound level *1 **	Indoor	dB(A)	Hi:40 Me:37 Lo:35	Hi:42 Me:40 Lo:37	Hi:43 Me:41 Lo:38	Hi:40 Me:37 Lo:35	Hi:42 Me:40 Lo:37	Hi:43 Me:41 Lo:38		
	Outdoor		49	Cooling:50 Heating:51	51	49	Cooling:50 Heating:51	51		
Air flow **	Indoor	CMM	Hi:27 Me:24 Lo:20	Hi:30 Me:27 Lo:23	Hi:30 Me:27 Lo:23	Hi:27 Me:24 Lo:20	Hi:30 Me:27 Lo:23	Hi:30 Me:27 Lo:23		
	Outdoor		Cooling:75 Heating:73			Cooling:75 Heating:73				
Indoor unit	Exterior dimensions	Height x Width x Depth	Unit:298x840x840 Panel:35x950x950							
	Net weight	kg	32.5(Unit:27 Panel:5.5)							
	Panel	Unit+Panel	T-PSA-3AW-E							
	Air filter, Q'ty		Pocket Plastic net x1 (Washable)							
	Remote control(option)		Wired:RC-E4, RCH-E3 Wireless:RCN-T-36W-E							
Outdoor unit	Exterior dimensions	Height x Width x Depth	845x970x370							
	Net weight	kg	81					83		
	Type of compressor		Rotary							
	Ref.amount precharged	kg(m)	3.8(30)							
Range of usage	Ref.piping size	Liquid/Gas	ø					9.52/15.88		
	Ref.piping length	m	50							
	Vertical height difference	O/U is higher	m	30						
		O/U is lower	m	15						
Operating temperature range	Cooling	O/U	-15~43*2							
	Heating	O/U	-20~20							

The data are measured under the following conditions(ISO-T1).

Cooling:Indoor temp. of 27°CDB, 19°CWB, and outdoor temp. of 35°CDB. Heating:Indoor temp. of 20°CDB, and outdoor temp. of 7°CDB, 6°CWB.

*1 : Indicates the value in an anechoic chamber. During operation these values are somewhat higher due to ambient conditions.

*2 : If a cooling operation is conducted when the outdoor air temperature is -5°C or lower, the outdoor unit should be installed at a place where it is not influenced by natural wind. If wind blows, the low pressure will drop and compressor frequency will increase, this will cause the capacity to drop and may cause the unit to break down.

** Powerful-Hi can be selected. Sound level: 100/125/140VNVD 51dB, 100/125/140VSVD 51dB

Air flow: 100/125/140VNVD 37CMM, 100/125/140VSVD 37CMM

DUCT CONNECTED -High Static pressure- FDU

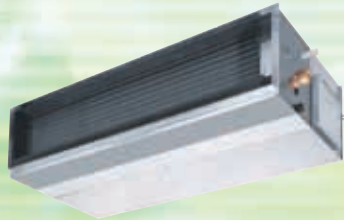

FDU 100/125/140VD



RC-E4 (Option) RCH-E3 (Option)



FDU 200/250VD



RCN-KIT3-E (Option)

Fan control kit (100~200Pa)



U-FCRA [For 200/250VD] (option)

SPECIFICATIONS

*Not available in 60Hz

		Micro Inverter			
		*FDU100VNVD	*FDU125VNVD		
Set model name		FDU100VD	FDU125VD		
Indoor name		FDC100VN	FDC125VN		
Outdoor name		1Phase 220-240V 50Hz			
Power source		1Phase 220-240V 50Hz			
Nominal cooling capacity (Min~Max)	ISO-T1 (JIS) kW	10.0 (4.0~11.2)	12.5 (5.0~14.0)		
Nominal heating capacity (Min~Max)	ISO-T1 (JIS) kW	11.2 (4.0~12.5)	14.0 (4.0~16.0)		
Power Consumption	Cooling/Heating kW	2.88/2.99	4.04/3.79		
COP	Cooling/Heating	3.47/3.75	3.09/3.69		
Energy label	Cooling/Heating	A/A	B/A		
Inrush current (Max. running current)	A	5(25)	5(27)		
Sound level *1	Indoor	Hi:42 Lo:37	Hi:43 Lo:38		
	Outdoor	49	Cooling:50 Heating:51		
Air flow	Indoor	Hi:34 Lo:27	Hi:42 Lo:33.5		
	Outdoor	Cooling:75 Heating:73			
External static pressure	Pa	Standard:50, Max:130			
Indoor unit	Exterior dimensions	Height x Width x Depth	mm	350x1,370x650	
	Net weight	kg		63	
	Air filter, Q'ty			Procure locally	
	Remote control(option)			Wired:RC-E4, RCH-E3 Wireless:RCN-KIT3-E	
Outdoor unit	Exterior dimensions	Height x Width x Depth	mm	845x970x370	
	Net weight	kg		81	
	Type of compressor			Rotary	
	Ref.amount precharged	kg(m)		3.8(30)	
Range of usage	Ref.piping size	Liquid/Gas	∅	9.52/15.88	
	Ref.piping length	m		50	
	Vertical height difference	O/U is higher	m		30
		O/U is lower	m		15
Operating temperature range	Cooling	O/U		-15~43*3	
	Heating	O/U		-20~20	

SPECIFICATIONS

		Micro Inverter						
		*FDU140VNVD	*FDU100VSVD	*FDU125VSVD	*FDU140VSVD	FDU200VSVD	FDU250VSVD	
Set model name		FDU140VD	FDU100VD	FDU125VD	FDU140VD	FDU200VD	FDU250VD	
Indoor name		FDC140VN	FDC100VS	FDC125VS	FDC140VS	FDC200VS	FDC250VS	
Outdoor name		1Phase 220-240V 50Hz		3Phase 380-415V 50Hz		3Phase 380-415V 50Hz, 3Phase 380V 60Hz		
Power source		1Phase 220-240V 50Hz		3Phase 380-415V 50Hz		3Phase 380-415V 50Hz, 3Phase 380V 60Hz		
Nominal cooling capacity (Min~Max)	ISO-T1 (JIS) kW	14.0 (5.0~14.5)	10.0 (4.0~11.2)	12.5 (5.0~14.0)	14.0 (5.0~14.5)	20.0 (7.0~22.4)	25.0 (10.0~28.0)	
Nominal heating capacity (Min~Max)	ISO-T1 (JIS) kW	16.0 (4.0~16.5)	11.2 (4.0~12.5)	14.0 (4.0~16.0)	16.0 (4.0~16.5)	22.4 (7.6~25.0)	28.0 (9.5~31.5)	
Power Consumption	Cooling/Heating kW	4.95/4.43	2.88/2.99	4.04/3.79	4.95/4.43	50Hz:6.59/6.08 60Hz:6.58/5.84	50Hz: 9.91/8.50 60Hz:10.21/8.22	
COP	Cooling/Heating	2.83/3.61	3.47/3.75	3.09/3.69	2.83/3.61	50Hz:3.03/3.68 60Hz:3.04/3.83	50Hz:2.52/3.29 60Hz:2.45/3.41	
Energy label	Cooling/Heating	C/A	A/A	B/A	C/A	B/A	50Hz:E/C 60Hz:E/B	
Inrush current (Max. running current)	A	5(28)	5(16)	5(18)	5(19)	5(24)	5(27)	
Sound level *1	Indoor	Hi:43 Lo:38	Hi:42 Lo:37	Hi:43 Lo:38		51	52	
	Outdoor	51	49	Cooling:50 Heating:51	51	57	Cooling:57 Heating:58	
Air flow	Indoor	Hi:42 Lo:33.5	Hi:34 Lo:27	Hi:42 Lo:33.5		50Hz:51, 60Hz:60	50Hz:68, 60Hz:80	
	Outdoor	Cooling:75 Heating:73		Cooling:150 Heating:145		Cooling:150 Heating:145		
External static pressure *2	Pa	Standard:50, Max:130		Standard:100, Max:200		Standard:100, Max:200		
Indoor unit	Exterior dimensions	Height x Width x Depth	mm	350x1,370x650		360x1,570x830		
	Net weight	kg		63		92		
	Air filter, Q'ty			Procure locally		Procure locally		
	Remote control(option)			Wired:RC-E4, RCH-E3 Wireless:RCN-KIT3-E		Wired:RC-E4, RCH-E3 Wireless:RCN-KIT3-E		
Outdoor unit	Exterior dimensions	Height x Width x Depth	mm	845x970x370		1,300x970x370		
	Net weight	kg		81	83	122	140	
	Type of compressor			Rotary		Scroll		
	Ref.amount precharged	kg(m)		3.8(30)		5.4(30)	7.2(30)	
Range of usage	Ref.piping size	Liquid/Gas	∅	9.52/15.88		9.52/25.4	12.7/25.4	
	Ref.piping length	m		50		70		
	Vertical height difference	O/U is higher	m		30		30	
		O/U is lower	m		15		15	
Operating temperature range	Cooling	O/U		-15~43 *3		-15~43 *3		
	Heating	O/U		-20~20		-15~20		

The data are measured under the following conditions(ISO-T1).

Cooling:Indoor temp. of 27°CDB, 19°CWB, and outdoor temp. of 35°CDB. Heating:Indoor temp. of 20°CDB, and outdoor temp. of 7°CDB, 6°CWB. External static pressure of FDU100/125/140 is 60Pa and that of FDU200/250 is 100Pa.

*1 : Indicates the value in an anechoic chamber. During operation these values are somewhat higher due to ambient conditions.

*2 : External static pressure is changeable to be set by the remote control. Standard external static pressure is factory setting. MAX external static pressure is "High static pressure" setting. The values of sound pressure level become 5dB(A) higher at external static pressure of 130Pa.

*3 : If a cooling operation is conducted when the outdoor air temperature is -5°C or lower, the outdoor unit should be installed at a place where it is not influenced by natural wind. If wind blows, the low pressure will drop and compressor frequency will increase, this will cause the capacity to drop and may cause the unit to break down.

Micro Inverter [INDOOR UNIT]

DUCT CONNECTED -Low/Middle Static pressure-

FDUM

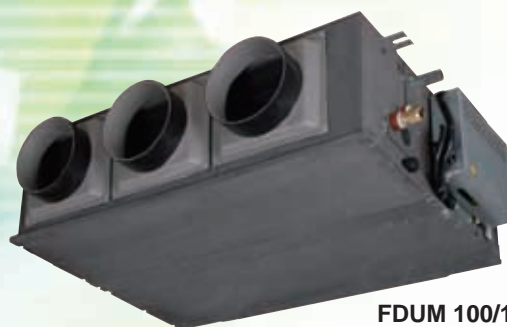

FDUM 100/125/140VD



Filter kit
UM-FL3E : for 100, 125, 140
(option)

external static pressure loss:5pa

Wired remote control



RC-E4
(Option)



RCH-E3
(Option)

Wireless remote control



RCN-KIT3-E
(Option)

SPECIFICATIONS

			Micro Inverter						
			FDUM100VNVD	FDUM125VNVD	FDUM140VNVD	FDUM100VSVD	FDUM125VSVD	FDUM140VSVD	
Set model name			FDUM100VD	FDUM125VD	FDUM140VD	FDUM100VD	FDUM125VD	FDUM140VD	
Indoor name			FDC100VN	FDC125VN	FDC140VN	FDC100VS	FDC125VS	FDC140VS	
Outdoor name			1Phase 220-240V 50Hz, 1Phase 220V 60Hz			3Phase 380-415V 50Hz, 3Phase 380V 60Hz			
Power source			1Phase 220-240V 50Hz, 1Phase 220V 60Hz			3Phase 380-415V 50Hz, 3Phase 380V 60Hz			
Nominal cooling capacity (Min~Max)	ISO-T1(JIS)	kW	10.0 (4.0~11.2)	12.5 (5.0~14.0)	14.0 (5.0~14.5)	10.0 (4.0~11.2)	12.5 (5.0~14.0)	14.0 (5.0~14.5)	
Nominal heating capacity (Min~Max)	ISO-T1(JIS)	kW	11.2 (4.0~12.5)	14.0 (4.0~16.0)	16.0 (4.0~16.5)	11.2 (4.0~12.5)	14.0 (4.0~16.0)	16.0 (4.0~16.5)	
Power Consumption	Cooling/Heating	kW	50Hz:2.80/2.77	50Hz:4.03/3.80	50Hz:4.95/4.89	50Hz:2.80/2.77	50Hz:4.03/3.80	50Hz:4.95/4.89	
			60Hz:2.80/2.80	60Hz:4.03/3.85	60Hz:4.95/4.91	60Hz:2.80/2.80	60Hz:4.03/3.85	60Hz:4.95/4.91	
COP	Cooling/Heating		50Hz:3.57/4.04	50Hz:3.10/3.68	50Hz:2.83/3.27	50Hz:3.57/4.04	50Hz:3.10/3.68	50Hz:2.83/3.27	
			60Hz:3.57/4.00	60Hz:3.10/3.64	60Hz:2.83/3.26	60Hz:3.57/4.00	60Hz:3.10/3.64	60Hz:2.83/3.26	
Energy label	Cooling/Heating		A/A	B/A	C/C	A/A	B/A	C/C	
Inrush current (Max. running current)		A	5(24)			5(15)			
Sound level *1 **	Indoor	dB(A)	Hi:37 Me:35 Lo:32	Hi:38 Me:36 Lo:33		Hi:37 Me:35 Lo:32	Hi:38 Me:36 Lo:33		
	Outdoor		49	Cooling:50 Heating:51	51	49	Cooling:50 Heating:51	51	
Air flow **	Indoor	CMM	Hi:28 Me:25 Lo:22						
	Outdoor		Cooling:75 Heating:73						
Static pressure		Pa	Standard:60, Max:90/100	Standard:60/55, Max:85/100		Standard:60, Max:90/100	Standard:60/55, Max:85/100		
Indoor unit	Exterior dimensions	Height x Width x Depth	350x1,370x635						
	Net weight	kg	59						
	Air filter, Q'ty		Procure locally						
	Remote control(option)		Wired:RC-E4, RCH-E3 Wireless:RCN-KIT3-E						
Range of Usage	Exterior dimensions	Height x Width x Depth	845x970x370						
			Net weight	81		83			
	Type of compressor	Rotary							
	Ref.amount precharged	kg(m)	3.8(30)						
	Ref.piping size	Liquid/Gas	ø						
	Ref.piping length	m	9.52/15.88						
	Vertical height difference	O/U is higher	m	50					
		O/U is lower	m	30					
Operating temperature range	Cooling	O/U	-15~43*2						
	Heating	O/U	-20~20						

The data are measured under the following conditions(ISO-T1).

Cooling:Indoor temp. of 27°CDB, 19°CWB, and outdoor temp. of 35°CDB. Heating:Indoor temp. of 20°CDB, and outdoor temp. of 7°CDB, 6°CWB. External static pressure of indoor units is 60Pa.

*1 : Indicates the value in an anechoic chamber. During operation these values are somewhat higher due to ambient conditions.

*2 : If a cooling operation is conducted when the outdoor air temperature is -5°C or lower, the outdoor unit should be installed at a place where it is not influenced by natural wind. If wind blows, the low pressure will drop and compressor frequency will increase, this will cause the capacity to drop and may cause the unit to break down.

** Powerful-Hi can be selected. Sound level: 100/125/140VNVD 41dB, 100/125/140VSVD 41dB

Air flow: 100/125/140VNVD 34CMM, 100/125/140VSVD 34CMM

CEILING SUSPENDED FDEN



FDEN 100/125/140VD

Wired remote control



RC-E4
(Option)



RCH-E3
(Option)

Wireless remote control



RCN-E1R
(Option)

SPECIFICATIONS

		Micro Inverter						
Set model name		FDEN100VNVD	FDEN125VNVD	FDEN140VNVD	FDEN100VSVD	FDEN125VSVD	FDEN140VSVD	
Indoor name		FDEN100VD	FDEN125VD	FDEN140VD	FDEN100VD	FDEN125VD	FDEN140VD	
Outdoor name		FDC100VN	FDC125VN	FDC140VN	FDC100VS	FDC125VS	FDC140VS	
Power source		1Phase 220-240V 50Hz, 1Phase 220V 60Hz			3Phase 380-415V 50Hz, 3Phase 380V 60Hz			
Nominal cooling capacity (Min~Max)	ISO-T1(JIS)	kW	10.0	12.5	14.0	10.0	12.5	14.0
			(4.0~11.2)	(5.0~14.0)	(5.0~14.5)	(4.0~11.2)	(5.0~14.0)	(5.0~14.5)
Nominal heating capacity (Min~Max)	ISO-T1(JIS)	kW	11.2	14.0	16.0	11.2	14.0	16.0
			(4.0~12.5)	(4.0~16.0)	(4.0~16.5)	(4.0~12.5)	(4.0~16.0)	(4.0~16.5)
Power Consumption	Cooling/Heating	kW	2.85/2.97	4.45/4.08	5.80/4.92	2.85/2.97	4.45/4.08	5.80/4.92
COP	Cooling/Heating		3.51/3.77	2.80/3.43	2.41/3.25	3.51/3.77	2.80/3.43	2.41/3.25
Energy label	Cooling/Heating		A/A	C/B	E/C	A/A	C/B	E/C
Inrush current (Max. running current)		A	5(24)			5(15)		
Sound level *1 ※	Indoor	dB(A)	Hi:44 Me:41 Lo:39	Hi:46 Me:44 Lo:43		Hi:44 Me:41 Lo:39	Hi:46 Me:44 Lo:43	
	Outdoor		49	Cooling:50 Heating:51	51	49	Cooling:50 Heating:51	51
Air flow ※	Indoor	CMM	Hi:26 Me:23 Lo:21	Hi:29 Me:26 Lo:23		Hi:26 Me:23 Lo:21	Hi:29 Me:26 Lo:23	
	Outdoor		Cooling:75 Heating:73					
Exterior dimensions	Height x Width x Depth	mm	250x1,620x690					
Net weight		kg	49					
Air filter, Q'ty			Pocket Plastic net x2 (Washable)					
Remote control(option)			Wired:RC-E4, RCH-E3 Wireless:RCN-E1R					
Exterior dimensions	Height x Width x Depth	mm	845x970x370					
Net weight		kg	81		83			
Type of compressor			Rotary					
Ref.amount precharged		kg(m)	3.8(30)					
Ref.piping size	Liquid/Gas	ø	9.52/15.88					
Range of usage	Ref.piping length	m	50					
	Vertical height difference	O/U is higher	30					
		O/U is lower	15					
Operating temperature range	Cooling	O/U	-15~43*2					
	Heating	O/U	-20~20					

The data are measured under the following conditions(ISO-T1).

Cooling:Indoor temp. of 27°CDB, 19°CWB, and outdoor temp. of 35°CDB.

Heating:Indoor temp. of 20°CDB, and outdoor temp. of 7°CDB, 6°CWB.

*1 : Indicates the value in an anechoic chamber. During operation these values are somewhat higher due to ambient conditions.

*2 : If a cooling operation is conducted when the outdoor air temperature is -5°C or lower, the outdoor unit should be installed at a place where it is not influenced by natural wind. If wind blows, the low pressure will drop and compressor frequency will increase, this will cause the capacity to drop and may cause the unit to break down.

※ Powerful-Hi can be selected. Sound level: 100VNVD 46dB, 125/140VNVD 50dB, 100VSVD 46dB, 125/140VSVD 50dB
Air flow: 100VNVD 28CMM, 125/140VNVD 32CMM, 100VSVD 28CMM, 125/140VSVD 32CMM

MULTI SYSTEM



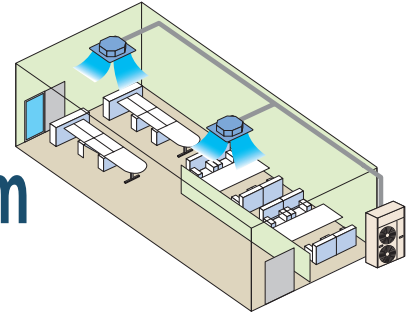

Up to Four indoor units can be connected to a single outdoor unit and simultaneously operated with a single remote control.

Twin / Triple / Double Twin Multi System





By referring to the following table for applicable indoor units, select the same models and capacities.



Applicable indoor units

Model	Capacity						Combination		
	40	50	60	71	100	125	Twin	Triple	Double Twin
4way FDT 	●	●	●	●	●	●	●	●	●
4way compact (600 x 600mm) FDTC 	●	●	●				●	●	●
Low/Middle Static pressure FDUM 		●	●	●	●	●	●	●	
Ceiling Suspended FDEN 	●	●	●	●	●	●	●	●	●
Wall Mounted SRK  Only used with outdoor units of Multi System		●	●				●	●	

Combination of indoor units

Outdoor Unit	Hyper Inverter				Micro Inverter				
		NEW 							
	FDC71VNX	FDC100VNX FDC100VSV	FDC125VNX FDC125VSV	FDC140VNX FDC140VSV	FDC100VNV FDC100VSV	FDC125VNV FDC125VSV	FDC140VNV FDC140VSV	FDC200VSV	FDC250VSV
Twin	40 + 40	50 + 50	60 + 60	71 + 71	50 + 50	60 + 60	71 + 71	100 + 100	125 + 125
Triple				50 + 50 + 50			50 + 50 + 50	71 + 71 + 71	
Double Twin								50+50+50+50	60+60+60+60

Decision of piping specification

Diagrams below show the application as samples. For further information, refer to TECHNICAL MANUAL.

Twin type

Models FDC71VNX, FDC100~140VNV/VSV
[Branch pipe set : DIS-WA1]

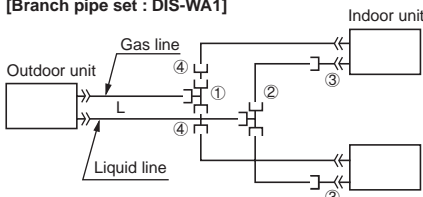

(Example)

Item	Indoor unit combinations	Liquid pipe		Gas pipe	
		Main pipe	Branch pipe	Main pipe	Branch pipe
FDC71	40+40				
FDC100	50+50	ø9.52Xt0.8	ø9.52Xt0.8	ø15.88Xt1.0	ø12.7Xt0.8
FDC125	60+60				ø15.88Xt1.0
FDC140	71+71				ø15.88Xt1.0

Notes (1) When 40-60 models of indoor units are applied to this combination, the reducer ③ supplied with the branch piping set should be used in order to reduce the liquid piping size from ø9.52mm to ø6.35mm at indoor unit side (flare connection). Accordingly be sure to select the liquid piping size ø9.52mm from branch to indoor unit.
(2) The reducer ④ is for FDC71 and 100 models only.

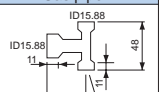
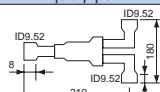
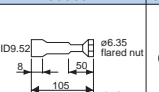
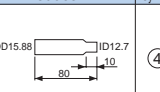
Chart of shapes of branch piping parts (DIS-WA1)	Gas pipe		Liquid pipe		Reducer		Reducer	
	Symbol	Symbol	Symbol	Symbol	Symbol	Symbol	Symbol	
	①		②		③		④	

Notes (1) Symbol ① to ④ in the drawing shows the symbols of branch piping parts in the chart respectively.
(2) Branch piping should always be arranged to have level or perpendicular position.

The branch piping (both gas and liquid lines) should always be arranged to have a level or perpendicular position.

2-Way Branch

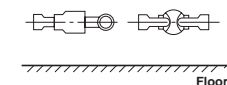

Mount — sections level with the floor.

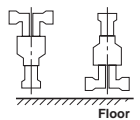

Mount — sections perpendicular to the floor.

3-Way Branch

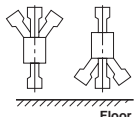
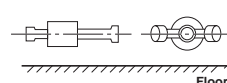

Ideal for the installation in large area and L-shaped rooms, the V Multi System has an extensive degree of flexibility in the selection of indoor units. Specifically, the selection of indoor units with different capacities in different types can be made.

V Multi System

Different models and capacities can be selected.

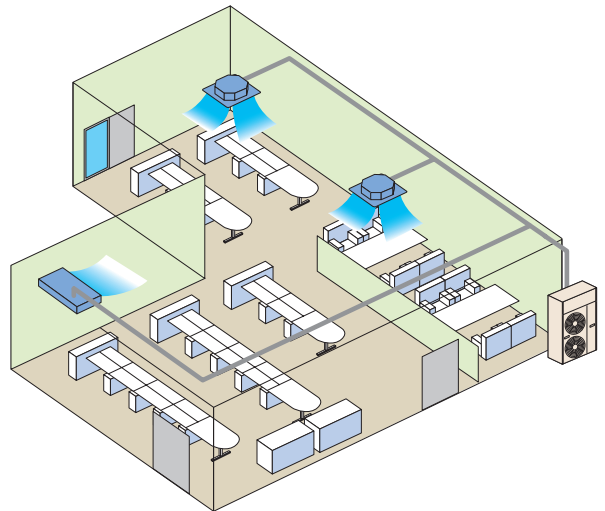

Applicable indoor units

Model	Capacity	40	50	60	71	100	125
4way FDT		●	●	●	●	●	●
Ceiling Suspended FDEN		●	●	●	●	●	●

Combination of indoor units

Outdoor Unit	NEW					
Hyper Inverter	FDC71VNX	FDC100VNX FDC100VSX	FDC125VNX FDC125VSX	FDC140VNX FDC140VSX	—	—
Micro Inverter	—	FDC100VNV FDC100VSV	FDC125VNV FDC125VSV	FDC140VNV FDC140VSV	FDC200VSV	FDC250VSV
Twin	40 + 40	50 + 50	60 + 60 50 + 71	71 + 71	100 + 100 71 + 125	125 + 125
Triple				50 + 50 + 50	71 + 71 + 71	60 + 60 + 125 71 + 71 + 100
Double Twin					50+50+50+50	60+60+60+60

Triple type

The indoor_outdoor piping length differences among indoor units are less than 3m.

Model FDC140VNV/VSV
[Branch pipe set : DIS-TA1]

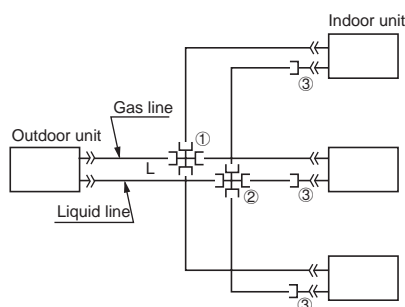

(Example)

Model	Item	Indoor unit combinations	Liquid pipe		Gas pipe	
			Main pipe	Branch pipe	Main pipe	Branch pipe
FDC140		50+50+50	ø9.52Xt0.8	ø9.52Xt0.8	ø15.88Xt1.0	ø12.7Xt0.8

Notes (1) The reducer ③ supplied with the branch piping set should be used in order to reduce the liquid piping size from ø9.52mm to ø6.35mm at indoor unit side (flare connection). Accordingly be sure to select the liquid piping size ø9.52mm from branch to indoor unit.

Chart of shapes of branch piping parts (DIS-TA1)	Gas pipe		Liquid pipe		Reducer	
	Symbol	Symbol	Symbol	Symbol	Symbol	Symbol
	①	②	③	④	⑤	⑥

Notes (1) Symbol ① to ③ in the drawing shows the symbols of branch piping parts in the chart respectively.
(2) Branch piping should always be arranged to have level or perpendicular position.

MULTI [INDOOR UNIT]

CEILING CASSETTE -4way-

FDT



FDT 40/50/60/71/100/125VD

Wired remote control



RC-E4
(Option)



RCH-E3
(Option)

Wireless remote control



RCN-T-36W-E
(Option)



SPECIFICATIONS

The values are for simultaneous Multi operation.

			Hyper Inverter	
Set model name			FDT71VNX PVD	FDT100VNX PVD
			Twin	
Indoor name			FDT40VD	FDT50VD
Outdoor name			FDC71VNX	FDC100VNX
Power source			1Phase 220-240V 50Hz, 1Phase 220V 60Hz	
Nominal cooling capacity (Min~Max)	ISO-T1(JIS)	kW	7.1 (3.2~8.0)	10.0 (4.0~11.2)
Nominal heating capacity (Min~Max)	ISO-T1(JIS)	kW	8.0 (3.6~9.0)	11.2 (4.0~12.5)
Power Consumption	Cooling/Heating	kW	1.85/1.99	2.56/2.66
COP	Cooling/Heating		3.84/4.02	3.91/4.21
Energy label	Cooling/Heating		A/A	A/A
Inrush current (Max. running current)		A	5(17)	5(24)
Sound level*1 ※	Indoor*2	dB(A)	Hi:33 Me:31 Lo:30	
	Outdoor		Cooling:51 Heating:48 Cooling:48 Heating:50	
Air flow ※	Indoor*2	CMM	Hi:18 Me:16 Lo:14	
	Outdoor		Cooling:60 Heating:50 100	
Indoor unit	Exterior dimensions	Height x Width x Depth	Unit:246x840x840 Panel:35x950x950	
	Net weight	Unit+Panel	27.5(Unit:22 Panel:5.5)	
	Panel		T-PSA-3AW-E	
	Air filter, Q'ty		Pocket Plastic net x1 (Washable)	
Outdoor unit	Remote control(option)		Wired:RC-E4, RCH-E3 Wireless:RCN-T-36W-E	
	Exterior dimensions	Height x Width x Depth	750x880(+88)x340 1,300x970x370	
	Net weight	kg	60 105	
	Ref.amount precharged	kg(m)	2.95(30) 4.5(30)	
Range of usage	Ref.piping size	Liquid/Gas	ø 9.52/15.88	
	Ref.piping length	m	50 100	
	Vertical height difference	O/U is higher	m 30	
		O/U is lower	m 15	
Operating temperature range	Cooling	O/U	-15~43*3	
	Heating	O/U	-20~20	

SPECIFICATIONS

The values are for simultaneous Multi operation.

			Hyper Inverter						
Set model name			FDT125VNX PVD	FDT140VNX PVD	FDT140VNX TVD	FDT100VXS PVD	FDT125VXS PVD	FDT140VXS PVD	FDT140VXS TVD
			Twin		Triple	Twin			Triple
Indoor name			FDT60VD	FDT71VD	FDT50VD	FDT50VD	FDT60VD	FDT71VD	FDT50VD
Outdoor name			FDC125VNX	FDC140VNX	FDC140VNX	FDC100VXS	FDC125VXS	FDC140VXS	FDC140VXS
Power source			1Phase 220-240V 50Hz, 1Phase 220V 60Hz			3Phase 380-415V 50Hz, 3Phase 380V 60Hz			
Nominal cooling capacity (Min~Max)	ISO-T1(JIS)	kW	12.5 (5.0~14.0)	14.0 (5.0~16.0)	14.0 (5.0~16.0)	10.0 (4.0~11.2)	12.5 (5.0~14.0)	14.0 (5.0~14.5)	14.0 (5.0~14.5)
Nominal heating capacity (Min~Max)	ISO-T1(JIS)	kW	14.0 (4.0~17.0)	16.0 (4.0~18.0)	16.0 (4.0~18.0)	11.2 (4.0~16.0)	14.0 (4.0~18.0)	16.0 (4.0~20.0)	16.0 (4.0~20.0)
Power Consumption	Cooling/Heating	kW	3.06/3.22	3.88/3.70	3.88/3.76	2.56/2.66	3.06/3.22	3.88/3.70	3.88/3.76
COP	Cooling/Heating		4.08/4.35	3.61/4.32	3.61/4.26	3.91/4.21	4.08/4.35	3.61/4.32	3.61/4.26
Energy label	Cooling/Heating		A/A	A/A	A/A	A/A	A/A	A/A	A/A
Inrush current (Max. running current)		A	5(26)			5(15)			
Sound level*1 ※	Indoor*2	dB(A)	Hi:33 Me:31 Lo:30		Hi:35 Me:33 Lo:31	Hi:33 Me:31 Lo:30		Hi:33 Me:31 Lo:30	Hi:35 Me:33 Lo:31
	Outdoor		Cooling:48 Heating:50		Cooling:49 Heating:52	Cooling:48 Heating:50		Cooling:49 Heating:52	
Air flow ※	Indoor*2	CMM	Hi:18 Me:16 Lo:14		Hi:21 Me:19 Lo:17	Hi:18 Me:16 Lo:14		Hi:21 Me:19 Lo:17	Hi:18 Me:16 Lo:14
	Outdoor		100		100		100		100
Indoor unit	Exterior dimensions	Height x Width x Depth	Unit:246x840x840 Panel:35x950x950						
	Net weight	Unit+Panel	29.5(Unit:24 Panel:5.5)		27.5(Unit:22 Panel:5.5)		29.5(Unit:24 Panel:5.5)		27.5(Unit:22 Panel:5.5)
	Panel		T-PSA-3AW-E						
	Air filter, Q'ty		Pocket Plastic net x1 (Washable)						
Outdoor unit	Remote control(option)		Wired:RC-E4, RCH-E3 Wireless:RCN-T-36W-E						
	Exterior dimensions	Height x Width x Depth	1,300x970x370						
	Net weight	kg	105						
	Ref.amount precharged	kg(m)	4.5(30)						
Range of usage	Ref.piping size	Liquid/Gas	ø 9.52/15.88						
	Ref.piping length	m	100						
	Vertical height difference	O/U is higher	m 30						
		O/U is lower	m 15						
Operating temperature range	Cooling	O/U	-15~43*3						
	Heating	O/U	-20~20						

The data are measured under the following conditions(ISO-T1).

Cooling:Indoor temp. of 27°CDB, 19°CWB, and outdoor temp. of 35°CDB. Heating:Indoor temp. of 20°CDB, and outdoor temp. of 7°CDB, 6°CWB.

*1 : Indicates the value in an anechoic chamber. During operation these values are somewhat higher due to ambient conditions.

*2 : The values are for one indoor unit operation.

*3 : If a cooling operation is conducted when the outdoor air temperature is -5°C or lower, the outdoor unit should be installed at a place where it is not influenced by natural wind. If wind blows, the low pressure will drop and compressor frequency will increase, this will cause the capacity to drop and may cause the unit to break down.

※ Powerful-Hi can be selected. Sound level: 71/100VNX PVD 39dB, 100VXS PVD 39dB, 125/140VNX PVD 46dB, 125/140VXS PVD 46dB, 140VNX TVD 39dB, 140VXS TVD 39dB

Air flow: 71/100VNX PVD 20CMM, 100VXS PVD 20CMM, 125/140VNX PVD 28CMM, 125/140VXS PVD 28CMM, 140VNX TVD 20CMM, 140VXS TVD 20CMM

SPECIFICATIONS The values are for simultaneous Multi operation.

			<i>Micro Inverter</i>							
Set model name			FDT100VNPVD	FDT125VNPVD	FDT140VNPVD	FDT140VNTVD	FDT100VSPVD	FDT125VSPVD	FDT140VSPVD	
			Twin			Triple		Twin		
Indoor name			FDT50VD	FDT60VD	FDT71VD	FDT50VD	FDT50VD	FDT60VD	FDT71VD	
Outdoor name			FDC100VN	FDC125VN	FDC140VN	FDC140VN	FDC100VS	FDC125VS	FDC140VS	
Power source			1Phase 220-240V 50Hz, 1Phase 220V 60Hz				3Phase 380-415V 50Hz, 3Phase 380V 60Hz			
Nominal cooling capacity (Min~Max)	ISO-T1(JIS)	kW	10.0 (4.0~11.2)	12.5 (5.0~14.0)	14.0 (5.0~14.5)	14.0 (5.0~14.5)	10.0 (4.0~11.2)	12.5 (5.0~14.0)	14.0 (5.0~14.5)	
Nominal heating capacity (Min~Max)	ISO-T1(JIS)	kW	11.2 (4.0~12.5)	14.0 (4.0~16.0)	16.0 (4.0~16.5)	16.0 (4.0~16.5)	11.2 (4.0~12.5)	14.0 (4.0~16.0)	16.0 (4.0~16.5)	
Power Consumption	Cooling/Heating	kW	2.94/3.09	3.95/3.70	4.51/4.58	4.65/4.63	2.94/3.09	3.95/3.70	4.51/4.58	
COP	Cooling/Heating		3.40/3.62	3.16/3.78	3.10/3.49	3.01/3.46	3.40/3.62	3.16/3.78	3.10/3.49	
Energy label	Cooling/Heating		A/A	B/A	B/B	B/B	A/A	B/A	B/B	
Inrush current (Max. running current)		A	5(24)				5(15)			
Sound level *1 ※	Indoor*2	dB(A)	Hi:33 Me:31 Lo:30	Hi:33 Me:31 Lo:30	Hi:35 Me:33 Lo:31	Hi:33 Me:31 Lo:30	Hi:33 Me:31 Lo:30	Hi:33 Me:31 Lo:30	Hi:35 Me:33 Lo:31	
	Outdoor		49	Cooling:50 Heating:51	51		49	Cooling:50 Heating:51	51	
Air flow ※	Indoor*2	CMM	Hi:18 Me:16 Lo:14		Hi:21 Me:19 Lo:17	Hi:18 Me:16 Lo:14	Hi:18 Me:16 Lo:14		Hi:21 Me:19 Lo:17	
	Outdoor		Cooling:75 Heating:73							
Indoor unit	Exterior dimensions	Height x Width x Depth	Unit:246x840x840 Panel:35x950x950							
	Net weight	Unit+Panel	27.5(Unit:22 Panel:5.5)	29.5(Unit:24 Panel:5.5)			27.5(Unit:22 Panel:5.5)	29.5(Unit:24 Panel:5.5)		
	Panel		T-PSA-3AW-E							
	Air filter, Q'ty		Pocket Plastic net x1 (Washable)							
Outdoor unit	Remote control(option)		Wired:RC-E4, RCH-E3 Wireless:RCN-T-36W-E							
	Exterior dimensions		845x970x370							
	Net weight	kg	81				83			
	Ref.amount precharged	kg(m)	3.8(30)							
Range of usage	Ref.piping size	Liquid/Gas	ø 9.52/15.88							
	Ref.piping length	m	50							
	Vertical height difference	O/U is higher	30							
		O/U is lower	15							
Operating temperature range	Cooling	O/U	-15~43*3							
	Heating	O/U	-20~20							

※ Powerful-Hi can be selected. Sound level: 100VNPVD 39dB, 125/140VNPVD 46dB, 140VNTVD 39dB, 100VSPVD 39dB, 125/140VSPVD 46dB
Air flow: 100VNPVD 20CMM, 125/140VNPVD 28CMM, 140VNTVD 20CMM, 100VSPVD 20CMM, 125/140VSPVD 28CMM

SPECIFICATIONS The values are for simultaneous Multi operation.

			<i>Micro Inverter</i>						
Set model name			FDT200VSPVD	FDT250VSPVD	FDT140VSTVD	FDT200VSTVD	FDT200VSDVD	FDT250VSDVD	
			Twin			Triple		Double Twin	
Indoor name			FDT100VD	FDT125VD	FDT50VD	FDT71VD	FDT50VD	FDT60VD	
Outdoor name			FDC200VS	FDC250VS	FDC140VS	FDC200VS	FDC200VS	FDC250VS	
Power source			3Phase 380-415V 50Hz, 3Phase 380V 60Hz						
Nominal cooling capacity (Min~Max)	ISO-T1(JIS)	kW	20.0 (7.0~22.4)	25.0 (10.0~28.0)	14.0 (5.0~14.5)	20.0 (7.0~22.4)	20.0 (7.0~22.4)	25.0 (10.0~28.0)	
Nominal heating capacity (Min~Max)	ISO-T1(JIS)	kW	22.4 (7.6~25.0)	28.0 (9.5~31.5)	16.0 (4.0~16.5)	22.4 (7.6~25.0)	22.4 (7.6~25.0)	28.0 (9.5~31.5)	
Power Consumption	Cooling/Heating	kW	6.58/6.02	8.30/7.75	4.65/4.63	6.49/6.12	6.58/6.15	8.28/7.70	
COP	Cooling/Heating		3.04/3.72	3.01/3.61	3.01/3.46	3.08/3.66	3.04/3.64	3.02/3.64	
Energy label	Cooling/Heating		B/A	B/A	B/B	B/A	B/A	B/A	
Inrush current (Max. running current)		A	5(19)	5(22)	5(15)	5(19)	5(19)	5(22)	
Sound level *1 ※	Indoor*2	dB(A)	Hi:40 Me:37 Lo:35	Hi:42 Me:40 Lo:37	Hi:33 Me:31 Lo:30	Hi:35 Me:33 Lo:31	Hi:33 Me:31 Lo:30	Hi:33 Me:31 Lo:30	
	Outdoor		57	Cooling:57 Heating:58	51	57	57	Cooling:57 Heating:58	
Air flow ※	Indoor*2	CMM	Hi:27 Me:24 Lo:20	Hi:30 Me:27 Lo:23	Hi:18 Me:16 Lo:14	Hi:21 Me:19 Lo:17	Hi:18 Me:16 Lo:14		
	Outdoor		Cooling:150 Heating:145						
Indoor unit	Exterior dimensions	Height x Width x Depth	Unit:298x840x840 Panel:35x950x950						
	Net weight	Unit+Panel	32.5(Unit:27 Panel:5.5)			27.5(Unit:22 Panel:5.5)	29.5(Unit:24 Panel:5.5)	27.5(Unit:22 Panel:5.5)	29.5(Unit:24 Panel:5.5)
	Panel		T-PSA-3AW-E						
	Air filter, Q'ty		Pocket Plastic net x1 (Washable)						
Outdoor unit	Remote control(option)		Wired:RC-E4, RCH-E3 Wireless:RCN-T-36W-E						
	Exterior dimensions	Height x Width x Depth	1,300x970x370		1,505x970x370	845x970x370	1,300x970x370		1,505x970x370
	Net weight	kg	122		140	83	122		140
	Ref.amount precharged	kg(m)	5.4(30)		7.2(30)	3.8(30)	5.4(30)		7.2(30)
Range of usage	Ref.piping size	Liquid/Gas	ø 9.52/22.22		12.7/22.22	ø 9.52/15.88	ø 9.52/22.22		12.7/22.22
	Ref.piping length	m	70		50	70			
	Vertical height difference	O/U is higher	30						
		O/U is lower	15						
Operating temperature range	Cooling	O/U	-15~43*3						
	Heating	O/U	-15~20		-20~20		-15~20		

The data are measured under the following conditions(ISO-T1).

Cooling:Indoor temp. of 27°CDB, 19°CWB, and outdoor temp. of 35°CDB. Heating:Indoor temp. of 20°CDB, and outdoor temp. of 7°CDB, 6°CWB.

*1 : Indicates the value in an anechoic chamber. During operation these values are somewhat higher due to ambient conditions.

*2 : The values are for one indoor unit operation.

*3 : If a cooling operation is conducted when the outdoor air temperature is -5°C or lower, the outdoor unit should be installed at a place where it is not influenced by natural wind. If wind blows, the low pressure will drop and compressor frequency will increase, this will cause the capacity to drop and may cause the unit to break down.

※ Powerful-Hi can be selected. Sound level: 200/250VSPVD 51dB, 140VSTVD 39dB, 200VSTVD 46dB, 200VSDVD 39dB, 250VSDVD 46dB
Air flow: 200/250VSPVD 37CMM, 140VSTVD 20CMM, 200VSTVD 28CMM, 200VSDVD 20CMM, 250VSDVD 28CMM

MULTI [INDOOR UNIT]

CEILING CASSETTE -4way Compact (600 X 600mm)-

FDTC



FDTC 40/50/60VD

Wired remote control



RC-E4
(Option)



RCH-E3
(Option)

Wireless remote control



RCN-TC-24W-ER
(Option)

SPECIFICATIONS The values are for simultaneous Multi operation.

		Hyper Inverter							
Set model name		FDTC71VNX PVD	FDTC100VNX PVD	FDTC125VNX PVD	FDTC140VNXTVD	FDTC100VXS PVD	FDTC125VXS PVD	FDTC140VXSXTVD	
		Twin			Triple	Twin			
Indoor name		FDTC40VD	FDTC50VD	FDTC60VD	FDTC50VD	FDTC50VD	FDTC60VD	FDTC50VD	
Outdoor name		FDC71VNX	FDC100VNX	FDC125VNX	FDC140VNX	FDC100VXS	FDC125VXS	FDC140VXS	
Power source		1Phase 220-240V 50Hz, 1Phase 220V 60Hz				3Phase 380-415V 50Hz, 3Phase 380V 60Hz			
Nominal cooling capacity (Min~Max)	ISO-T1(JIS)	kW	7.1 (3.2~8.0)	10.0 (4.0~11.2)	12.5 (5.0~14.0)	14.0 (5.0~16.0)	10.0 (4.0~11.2)	12.5 (5.0~14.0)	14.0 (5.0~16.0)
Nominal heating capacity (Min~Max)	ISO-T1(JIS)	kW	8.0 (3.6~9.0)	11.2 (4.0~12.5)	14.0 (4.0~17.0)	16.0 (4.0~18.0)	11.2 (4.0~16.0)	14.0 (4.0~18.0)	16.0 (4.0~20.0)
Power Consumption	Cooling/Heating	kW	1.99/2.18	2.78/3.02	4.10/4.10	4.34/4.34	2.78/3.02	4.10/4.10	4.34/4.34
COP	Cooling/Heating		3.57/3.67	3.60/3.71	3.05/3.41	3.23/3.69	3.60/3.71	3.05/3.41	3.23/3.69
Energy label	Cooling/Heating		A/A	A/A	B/B	A/A	A/A	B/B	A/A
Inrush current (Max. running current)	A		5(17)	5(24)	5(26)		5(15)		
Sound level *1 **	Indoor*2	dB(A)	Cooling : Hi:42 Me:36 Lo:30	Cooling : Hi:46 Me:39 Lo:30	Cooling : Hi:42 Me:36 Lo:30	Cooling : Hi:46 Me:39 Lo:30	Cooling : Hi:46 Me:39 Lo:30	Cooling : Hi:42 Me:36 Lo:30	Cooling : Hi:42 Me:36 Lo:30
	Outdoor		Heating : Hi:42 Me:36 Lo:32	Heating : Hi:46 Me:39 Lo:32	Heating : Hi:42 Me:36 Lo:32	Heating : Hi:46 Me:39 Lo:32	Heating : Hi:46 Me:39 Lo:32	Heating : Hi:42 Me:36 Lo:32	Heating : Hi:42 Me:36 Lo:32
Air flow **	Indoor*2	CMM	Cooling : Hi:11.5 Me:9 Lo:7	Cooling : Hi:13.5 Me:10 Lo:7	Cooling : Hi:11.5 Me:9 Lo:7	Cooling : Hi:13.5 Me:10 Lo:7	Cooling : Hi:13.5 Me:10 Lo:7	Cooling : Hi:11.5 Me:9 Lo:7	Cooling : Hi:11.5 Me:9 Lo:7
	Outdoor		Heating : Hi:11.5 Me:9 Lo:8	Heating : Hi:13.5 Me:10 Lo:8	Heating : Hi:11.5 Me:9 Lo:8	Heating : Hi:13.5 Me:10 Lo:8	Heating : Hi:13.5 Me:10 Lo:8	Heating : Hi:11.5 Me:9 Lo:8	Heating : Hi:11.5 Me:9 Lo:8
Indoor unit	Exterior dimensions	Height x Width x Depth	mm Unit:248x570x570 Panel:35x700x700						
	Net weight	Unit+Panel	kg 18.5(Unit:15 Panel:3.5)						
	Panel		TC-PSA-25W-E						
	Air filter, Q'ty		Pocket Plastic net x1 (Washable)						
	Remote control(option)		Wired:RC-E4, RCH-E3 Wireless:RCN-TC-24W-ER						
Outdoor unit	Exterior dimensions	Height x Width x Depth	mm 750x880(+88)x340						
	Net weight		kg 60						
	Ref.amount precharged		kg(m) 2.95(30)						
Range of usage	Ref.piping size	Liquid/Gas	ø 9.52/15.88						
	Ref.piping length		m 50						
	Vertical height difference	O/U is higher	m 30						
		O/U is lower	m 15						
Operating temperature range	Cooling	O/U	-15~43*3						
	Heating	O/U	-20~20						

The data are measured under the following conditions(ISO-T1).

Cooling:Indoor temp. of 27°CDB, 19°CWB, and outdoor temp. of 35°CDB. Heating:Indoor temp. of 20°CDB, and outdoor temp. of 7°CDB, 6°CWB.

*1 : Indicates the value in an anechoic chamber. During operation these values are somewhat higher due to ambient conditions.

*2 : The values are for one indoor unit operation.

*3 : If a cooling operation is conducted when the outdoor air temperature is -5°C or lower, the outdoor unit should be installed at a place where it is not influenced by natural wind. If wind blows, the low pressure will drop and compressor frequency will increase, this will cause the capacity to drop and may cause the unit to break down.

** Powerful-Hi can be selected. Sound level: 71/100/125VNX PVD 47dB, 100/125VXS PVD 47dB, 140VNXTVD 47dB, 140VXSXTVD 47dB

Air flow: 71/100/125VNX PVD 13.5CMM, 100/125VXS PVD 13.5CMM, 140VNXTVD 13.5CMM, 140VXSXTVD 13.5CMM

SPECIFICATIONS The values are for simultaneous Multi operation.

			<i>Micro Inverter</i>			
Set model name			FDTCT100VNPVD	FDTCT125VNPVD	FDTCT140VNTVD	
			Twin		Triple	
Indoor name			FDTCT50VD	FDTCT60VD	FDTCT50VD	
Outdoor name			FDC100VN	FDC125VN	FDC140VN	
Power source			1Phase 220-240V 50Hz, 1Phase 220V 60Hz			
Nominal cooling capacity (Min~Max)	ISO-T1(JIS)	kW	10.0 (4.0~11.2)	12.5 (5.0~14.0)	14.0 (5.0~14.5)	
Nominal heating capacity (Min~Max)	ISO-T1(JIS)	kW	11.2 (4.0~12.5)	14.0 (4.0~16.0)	16.0 (4.0~16.5)	
Power Consumption	Cooling/Heating	kW	2.84/3.08	5.35/4.62	4.64/4.52	
COP	Cooling/Heating		3.52/3.64	2.34/3.03	3.02/3.54	
Energy label	Cooling/Heating		A/A	F/D	B/B	
Inrush current (Max. running current)		A	5(24)	5(27)	5(24)	
Sound level *1 ※	Indoor*2	dB(A)	Cooling : Hi:42 Me:36 Lo:30 Heating : Hi:42 Me:36 Lo:32	Cooling : Hi:46 Me:39 Lo:30 Heating : Hi:46 Me:39 Lo:32	Cooling : Hi:42 Me:36 Lo:30 Heating : Hi:42 Me:36 Lo:32	
	Outdoor		49	Cooling:50 Heating:51	51	
Air flow ※	Indoor*2	CMM	Cooling : Hi:11.5 Me:9 Lo:7 Heating : Hi:11.5 Me:9 Lo:8	Cooling : Hi:13.5 Me:10 Lo:7 Heating : Hi:13.5 Me:10 Lo:8	Cooling : Hi:11.5 Me:9 Lo:7 Heating : Hi:11.5 Me:9 Lo:8	
	Outdoor		Cooling:75 Heating:73			
Indoor unit	Exterior dimensions	Height x Width x Depth	mm Unit:248x570x570 Panel:35x700x700			
	Net weight	Unit+Panel	kg 18.5(Unit:15 Panel:3.5)			
	Panel		TC-PSA-25W-E			
	Air filter, Q'ty		Pocket Plastic net x1 (Washable)			
	Remote control(option)		Wired:RC-E4, RCH-E3 Wireless:RCN-TC-24W-ER			
	Exterior dimensions	Height x Width x Depth	mm	845x970x370		
Outdoor unit	Net weight		kg 81			
	Ref.amount precharged		kg(m) 3.8(30)			
	Ref.piping size	Liquid/Gas	ø 9.52/15.88			
	Range of usage	Ref.piping length		m 50		
		Vertical height difference	O/U is higher	m 30		
			O/U is lower	m 15		
Operating temperature range	Cooling	O/U	-15~43*3			
	Heating	O/U	-20~20			

※ Powerful-Hi can be selected. Sound level: 100/125VNPVD 47dB, 140VNTVD 47dB
Air flow: 100/125VNPVD 13.5CMM, 140VNTVD 13.5CMM

SPECIFICATIONS The values are for simultaneous Multi operation.

			<i>Micro Inverter</i>					
Set model name			FDTCT100VSPVD	FDTCT125VSPVD	FDTCT140VSTVD	FDTCT200VSDVD	FDTCT250VSDVD	
			Twin		Triple	Double Twin		
Indoor name			FDTCT50VD	FDTCT60VD	FDTCT50VD	FDTCT50VD	FDTCT60VD	
Outdoor name			FDC100VS	FDC125VS	FDC140VS	FDC200VS	FDC250VS	
Power source			3Phase 380-415V 50Hz, 3Phase 380V 60Hz					
Nominal cooling capacity (Min~Max)	ISO-T1(JIS)	kW	10.0 (4.0~11.2)	12.5 (5.0~14.0)	14.0 (5.0~14.5)	20.0 (7.0~22.4)	25.0 (10.0~28.0)	
Nominal heating capacity (Min~Max)	ISO-T1(JIS)	kW	11.2 (4.0~12.5)	14.0 (4.0~16.0)	16.0 (4.0~16.5)	22.4 (7.6~25.0)	28.0 (9.5~31.5)	
Power Consumption	Cooling/Heating	kW	2.84/3.08	5.35/4.62	4.64/4.52	7.33/6.98	11.28/10.19	
COP	Cooling/Heating		3.52/3.64	2.34/3.03	3.02/3.54	2.73/3.21	2.22/2.75	
Energy label	Cooling/Heating		A/A	F/D	B/B	D/C	F/E	
Inrush current (Max. running current)		A	5(15)	5(15)	5(15)	5(19)	5(22)	
Sound level *1 ※	Indoor*2	dB(A)	Cooling : Hi:42 Me:36 Lo:30 Heating : Hi:42 Me:36 Lo:32	Cooling : Hi:46 Me:39 Lo:30 Heating : Hi:46 Me:39 Lo:32	Cooling : Hi:42 Me:36 Lo:30 Heating : Hi:42 Me:36 Lo:32	Cooling : Hi:46 Me:39 Lo:30 Heating : Hi:46 Me:39 Lo:32	Cooling : Hi:46 Me:39 Lo:30 Heating : Hi:46 Me:39 Lo:32	
	Outdoor		49	Cooling:50 Heating:51	51	57	Cooling:57 Heating:58	
Air flow ※	Indoor*2	CMM	Cooling : Hi:11.5 Me:9 Lo:7 Heating : Hi:11.5 Me:9 Lo:8	Cooling : Hi:13.5 Me:10 Lo:7 Heating : Hi:13.5 Me:10 Lo:8	Cooling : PHi:11.5 Me:9 Lo:7 Heating : Hi:11.5 Me:9 Lo:8	Cooling : Hi:13.5 Me:10 Lo:7 Heating : Hi:13.5 Me:10 Lo:8	Cooling : Hi:13.5 Me:10 Lo:7 Heating : Hi:13.5 Me:10 Lo:8	
	Outdoor		Cooling:75 Heating:73			Cooling:150 Heating:145		
Indoor unit	Exterior dimensions	Height x Width x Depth	mm Unit:248x570x570 Panel:35x700x700					
	Net weight	Unit+Panel	kg 18.5(Unit:15 Panel:3.5)					
	Panel		TC-PSA-25W-E					
	Air filter, Q'ty		Pocket Plastic net x1 (Washable)					
	Remote control(option)		Wired:RC-E4, RCH-E3 Wireless:RCN-TC-24W-ER					
	Exterior dimensions	Height x Width x Depth	mm	845x970x370		1,300x970x370		1,505x970x370
Outdoor unit	Net weight		kg 83		122		140	
	Ref.amount precharged		kg(m) 3.8(30)		5.4(30)		7.2(30)	
	Ref.piping size	Liquid/Gas	ø 9.52/15.88		9.52/22.22		12.7/22.22	
	Range of usage	Ref.piping length		m 50		70		
		Vertical height difference	O/U is higher	m 30				
			O/U is lower	m 15				
Operating temperature range	Cooling	O/U	-15~43*3					
	Heating	O/U	-20~20		-15~20			

The data are measured under the following conditions(ISO-T1).

Cooling:Indoor temp. of 27°CDB, 19°CWB, and outdoor temp. of 35°CDB. Heating:Indoor temp. of 20°CDB, and outdoor temp. of 7°CDB, 6°CWB.

*1 : Indicates the value in an anechoic chamber. During operation these values are somewhat higher due to ambient conditions.

*2 : The values are for one indoor unit operation.

*3 : If a cooling operation is conducted when the outdoor air temperature is -5°C or lower, the outdoor unit should be installed at a place where it is not influenced by natural wind. If wind blows, the low pressure will drop and compressor frequency will increase, this will cause the capacity to drop and may cause the unit to break down.

※ Powerful-Hi can be selected. Sound level: 100/125VSPVD 47dB, 140VSTVD 47dB, 200/250VSDVD 47dB
Air flow: 100/125VSPVD 13.5CMM, 140VSTVD 13.5CMM, 200/250VSDVD 13.5CMM

MULTI [INDOOR UNIT]

DUCT CONNECTED -Low/Middle Static pressure-

FDUM



FDUM 50/60/71/
100/125VD



external static pressure loss:5pa

Filter kit

UM-FL1E : for 50
UM-FL2E : for 60, 71
UM-FL3E : for 100, 125
(option)

Wired remote control



RC-E4
(Option)



RCH-E3
(Option)

Wireless remote control



RCN-KIT3-E
(Option)

SPECIFICATIONS

The values are for simultaneous Multi operation.

		Hyper Inverter	
Set model name		FDUM100VNX PVD	FDUM125VNX PVD
Twin			
Indoor name		FDUM50VD	FDUM60VD
Outdoor name		FDC100VNX	FDC125VNX
Power source		1Phase 220-240V 50Hz, 1Phase 220V 60Hz	
Nominal cooling capacity (Min~Max)	ISO-T1(JIS) kW	10.0 (4.0~11.2)	12.5 (5.0~14.0)
Nominal heating capacity (Min~Max)	ISO-T1(JIS) kW	11.2 (4.0~12.5)	14.0 (4.0~17.0)
Power Consumption	Cooling/Heating kW	2.94/2.94	3.86/4.10
COP	Cooling/Heating	3.40/3.81	3.24/3.41
Energy label	Cooling/Heating	A/A	A/B
Inrush current (Max. running current)	A	5(24)	5(26)
Sound level*1 ※	Indoor*2 Outdoor	dB(A) Hi:34 Me:31 Lo:28 Cooling:48 Heating:50	
Air flow ※	Indoor*2 Outdoor	CMM Hi:13 Me:12 Lo:11 Hi:16 Me:15 Lo:14 100	
Indoor unit	Exterior dimensions	Height x Width x Depth	mm 299x750x635
	Net weight	kg	34
Indoor unit	Air filter, Q'ty	Procure locally	
	Remote control(option)	Wired:RC-E4, RCH-E3 Wireless:RCN-KIT3-E	
Outdoor unit	Exterior dimensions	Height x Width x Depth	mm 1,300x970x370
	Net weight	kg	105
Outdoor unit	Ref.amount precharged	kg(m)	4.5(30)
	Ref.piping size	Liquid/Gas	ø 9.52/15.88
Range of usage	Ref.piping length	m	100
	Vertical height difference	O/U is higher	m 30
		O/U is lower	m 15
Operating temperature range	Cooling/Heating	O/U	-15~43*3 -20~20

SPECIFICATIONS

The values are for simultaneous Multi operation.

		Hyper Inverter					
Set model name		FDUM140VNX PVD	FDUM140VNX TVD	FDUM100VXS PVD	FDUM125VXS PVD	FDUM140VXS PVD	FDUM140VXS TVD
		Twin		Triple		Twin	
		Triple		Twin		Triple	
Indoor name		FDUM71VD	FDUM50VD	FDUM50VD	FDUM60VD	FDUM71VD	FDUM50VD
Outdoor name		FDC140VNX	FDC140VNX	FDC100VXS	FDC125VXS	FDC140VXS	FDC140VXS
Power source		1Phase 220-240V 50Hz, 1Phase 220V 60Hz		3Phase 380-415V 50Hz, 3Phase 380V 60Hz			
Nominal cooling capacity (Min~Max)	ISO-T1(JIS) kW	14.0 (5.0~16.0)	14.0 (5.0~16.0)	10.0 (4.0~11.2)	12.5 (5.0~14.0)	14.0 (5.0~16.0)	14.0 (5.0~16.0)
Nominal heating capacity (Min~Max)	ISO-T1(JIS) kW	16.0 (4.0~18.0)	16.0 (4.0~18.0)	11.2 (4.0~16.0)	14.0 (4.0~18.0)	16.0 (4.0~20.0)	16.0 (4.0~20.0)
Power Consumption	Cooling/Heating kW	4.60/4.69	4.60/4.69	2.94/2.94	3.86/4.10	4.60/4.69	4.60/4.69
COP	Cooling/Heating	3.04/3.41	3.04/3.41	3.40/3.81	3.24/3.41	3.04/3.41	3.04/3.41
Energy label	Cooling/Heating	B/B		A/A	A/B	B/B	B/B
Inrush current (Max. running current)	A	5(26)		5(15)			
Sound level*1 ※	Indoor*2 Outdoor	dB(A) Hi:35 Me:32 Lo:29 Cooling:49 Heating:52		Hi:34 Me:31 Lo:28 Cooling:48 Heating:50		Hi:35 Me:32 Lo:29 Cooling:49 Heating:52	
Air flow ※	Indoor*2 Outdoor	CMM Hi:20 Me:18 Lo:15 Hi:13 Me:12 Lo:11		Hi:13 Me:12 Lo:11 Hi:16 Me:15 Lo:14		Hi:20 Me:18 Lo:15 Hi:13 Me:12 Lo:11	
Indoor unit	Exterior dimensions	Height x Width x Depth	mm 299x950x635	299x750x635		299x950x635	
	Net weight	kg	40	34		40	
Indoor unit	Air filter, Q'ty	Procure locally					
	Remote control(option)	Wired:RC-E4, RCH-E3 Wireless:RCN-KIT3-E					
Outdoor unit	Exterior dimensions	Height x Width x Depth	mm 1,300x970x370				
	Net weight	kg	105				
Outdoor unit	Ref.amount precharged	kg(m)	4.5(30)				
	Ref.piping size	Liquid/Gas	ø 9.52/15.88				
Range of usage	Ref.piping length	m	100				
	Vertical height difference	O/U is higher	m 30				
		O/U is lower	m 15				
Operating temperature range	Cooling/Heating	O/U	-15~43*3 -20~20				

The data are measured under the following conditions(ISO-T1).

Cooling:Indoor temp. of 27°CDB, 19°CWB, and outdoor temp. of 35°CDB. Heating:Indoor temp. of 20°CDB, and outdoor temp. of 7°CDB, 6°CWB.

*1 : Indicates the value in an anechoic chamber. During operation these values are somewhat higher due to ambient conditions.

*2 : The values are for one indoor unit operation.

*3 : If a cooling operation is conducted when the outdoor air temperature is -5°C or lower, the outdoor unit should be installed at a place where it is not influenced by natural wind. If wind blows, the low pressure will drop and compressor frequency will increase, this will cause the capacity to drop and may cause the unit to break down.

※ Powerful-Hi can be selected. Sound level: 100VNX PVD 35dB, 100VXS PVD 35dB, 125/140VNX PVD 38dB, 125/140VXS PVD 38dB, 140VNX TVD 35dB, 140VXS TVD 35dB
Air flow: 100VNX PVD 14CMM, 100VXS PVD 14CMM, 125/140VNX PVD 18CMM, 125/140VXS PVD 18CMM, 140VNX TVD 14CMM, 140VXS TVD 14CMM

SPECIFICATIONS The values are for simultaneous Multi operation.

			Micro Inverter				
Set model name			FDUM100VNPVD	FDUM125VNPVD	FDUM140VNPVD	FDUM140VNTVD	FDUM100VSPVD
			Twin		Triple		
Indoor name			FDUM50VD	FDUM60VD	FDUM71VD	FDUM50VD	FDUM50VD
Outdoor name			FDC100VN	FDC125VN	FDC140VN	FDC140VN	FDC100VS
Power source			1Phase 220-240V 50Hz, 1Phase 220V 60Hz				3Phase 380-415V 50Hz, 3Phase 380V 60Hz
Nominal cooling capacity (Min~Max)	ISO-T1(JIS)	kW	10.0 (4.0~11.2)	12.5 (5.0~14.0)	14.0 (5.0~14.5)	14.0 (5.0~14.5)	10.0 (4.0~11.2)
Nominal heating capacity (Min~Max)	ISO-T1(JIS)	kW	11.2 (4.0~12.5)	14.0 (4.0~16.0)	16.0 (4.0~16.5)	16.0 (4.0~16.5)	11.2 (4.0~12.5)
Power Consumption	Cooling/Heating	kW	3.12/3.27	4.47/4.51	50Hz:5.00/4.94	50Hz:5.09/5.03	3.12/3.27
					60Hz:5.00/4.80	60Hz:5.09/4.89	
COP	Cooling/Heating		3.21/3.43	2.80/3.10	50Hz:2.80/3.24	50Hz:2.75/3.18	3.21/3.43
					60Hz:2.80/3.33	60Hz:2.75/3.27	
Energy label			A/B	C/D	C/C	50Hz:D/D 60Hz:D/C	A/B
Inrush current (Max. running current)			A 5(24)				5(15)
Sound level*1 ※	Indoor*2	dB(A)	Hi:34 Me:31 Lo:28	Hi:34 Me:31 Lo:28	Hi:35 Me:32 Lo:29	Hi:34 Me:31 Lo:28	49
	Outdoor		Cooling:50 Heating:51				
Air flow ※	Indoor*2	CMM	Hi:13 Me:12 Lo:11	Hi:16 Me:15 Lo:14	Hi:20 Me:18 Lo:15	Hi:13 Me:12 Lo:11	Cooling:75 Heating:73
	Outdoor						
Exterior dimensions			Height x Width x Depth		mm		299x750x635
Net weight			kg		mm		299x950x635
Air filter, Q'ty			kg		mm		34
Remote control(option)			Procure locally				
			Wired:RC-E4, RCH-E3 Wireless:RCN-KIT3-E				
Exterior dimensions			Height x Width x Depth		mm		845x970x370
Net weight			kg		mm		81
Ref.amount precharged			kg(m)		mm		83
Ref.piping size			Liquid/Gas		ø		3.8(30)
							9.52/15.88
Ref.piping length			m				50
Vertical height difference			O/U is higher		m		30
			O/U is lower		m		15
Operating temperature range			Cooling		O/U		-15~43*3
			Heating		O/U		-20~20

※ Powerful-Hi can be selected. Sound level: 100VNPVD 35dB, 125VNPVD 38dB, 140VNPVD 38dB, 140VNTVD 35dB, 100VSPVD 35dB
Air flow: 100VNPVD 14CMM, 125VNPVD 18CMM, 140VNPVD 23CMM, 140VNTVD 14CMM, 100VSPVD 14CMM

SPECIFICATIONS The values are for simultaneous Multi operation.

			Micro Inverter					
Set model name			FDUM125VSPVD	FDUM140VSPVD	FDUM200VSPVD	FDUM250VSPVD	FDUM140VSTVD	FDUM200VSTVD
			Twin		Triple			
Indoor name			FDUM60VD	FDUM71VD	FDUM100VD	FDUM125VD	FDUM50VD	FDUM71VD
Outdoor name			FDC125VS	FDC140VS	FDC200VS	FDC250VS	FDC140VS	FDC200VS
Power source			3Phase 380-415V 50Hz, 3Phase 380V 60Hz					
Nominal cooling capacity (Min~Max)	ISO-T1(JIS)	kW	12.5 (5.0~14.0)	14.0 (5.0~14.5)	20.0 (7.0~22.4)	25.0 (10.0~28.0)	14.0 (5.0~14.5)	20.0 (7.0~22.4)
Nominal heating capacity (Min~Max)	ISO-T1(JIS)	kW	14.0 (4.0~16.0)	16.0 (4.0~16.5)	22.4 (7.6~25.0)	28.0 (9.5~31.5)	16.0 (4.0~16.5)	22.4 (7.6~25.0)
Power Consumption	Cooling/Heating	kW	4.47/4.51	50Hz:5.00/4.94	6.86/6.72	9.31/8.35	50Hz:5.09/5.03	6.88/6.74
				60Hz:5.00/4.80			60Hz:5.09/4.89	
COP	Cooling/Heating		2.80/3.10	50Hz:2.80/3.24	2.92/3.33	2.69/3.35	50Hz:2.75/3.18	2.91/3.32
				60Hz:2.80/3.33			60Hz:2.75/3.27	
Energy label			C/D	C/C	C/C	D/C	50Hz:D/D 60Hz:D/C	C/C
Inrush current (Max. running current)			A 5(15)		5(19)	5(22)	5(15)	5(19)
Sound level*1 ※	Indoor*2	dB(A)	Hi:34 Me:31 Lo:28	Hi:35 Me:32 Lo:29	Hi:37 Me:35 Lo:32	Hi:38 Me:36 Lo:33	Hi:34 Me:31 Lo:28	Hi:35 Me:32 Lo:29
	Outdoor		Cooling:50 Heating:51				51	Cooling:57 Heating:58
Air flow ※	Indoor*2	CMM	Hi:16 Me:15 Lo:14	Hi:20 Me:18 Lo:15	Hi:28 Me:25 Lo:22	Hi:13 Me:12 Lo:11	Hi:20 Me:18 Lo:15	
	Outdoor		Cooling:75 Heating:73				Cooling:150 Heating:145	Cooling:150 Heating:145
Exterior dimensions			Height x Width x Depth		mm		299x950x635	
Net weight			kg		mm		350x1,370x635	
Air filter, Q'ty			kg		mm		299x750x635	
Remote control(option)			Procure locally					
			Wired:RC-E4, RCH-E3 Wireless:RCN-KIT3-E					
Exterior dimensions			Height x Width x Depth		mm		845x970x370	
Net weight			kg		mm		1,300x970x370	
Ref.amount precharged			kg(m)		mm		1,505x970x370	
Ref.piping size			Liquid/Gas		ø		845x970x370	
							1,300x970x370	
Ref.piping length			m				83	
Vertical height difference			O/U is higher		m		122	
			O/U is lower		m		140	
Operating temperature range			Cooling		O/U		3.8(30)	
			Heating		O/U		5.4(30)	
							7.2(30)	
							3.8(30)	
							5.4(30)	
Ref.piping length			m				50	
Vertical height difference			O/U is higher		m		70	
			O/U is lower		m		30	
Operating temperature range			Cooling		O/U		15	
			Heating		O/U		-15~43*3	
							-20~20	
							-20~20	
							-15~20	

The data are measured under the following conditions(ISO-T1).
Cooling:Indoor temp. of 27°CDB, 19°CWB, and outdoor temp. of 35°CDB. Heating:Indoor temp. of 20°CDB, and outdoor temp. of 7°CDB, 6°CWB. External static pressure of indoor units is 60Pa.

*1 : Indicates the value in an anechoic chamber. During operation these values are somewhat higher due to ambient conditions.

*2 : The values are for one indoor unit operation.

*3 : If a cooling operation is conducted when the outdoor air temperature is -5°C or lower, the outdoor unit should be installed at a place where it is not influenced by natural wind. If wind blows, the low pressure will drop and compressor frequency will increase, this will cause the capacity to drop and may cause the unit to break down.

※ Powerful-Hi can be selected. Sound level: 125/140VSPVD 38dB, 200/250VSPVD 41dB, 140VSTVD 35dB, 200VSTVD 38dB
Air flow: 125VSPVD 18CMM, 140VSPVD 23CMM, 200/250VSPVD 34CMM, 140VSTVD 14CMM, 200VSTVD 23CMM

MULTI [INDOOR UNIT]

CEILING SUSPENDED FDEN



FDEN 40/50/60/71/100/125VD

Wired remote control



RC-E4
(Option)



RCH-E3
(Option)

Wireless remote control



RCN-E1R
(Option)

SPECIFICATIONS

The values are for simultaneous Multi operation.

			Hyper Inverter		
Set model name			FDEN71VNX PVD	FDEN100VNX PVD	
			Twin		
Indoor name			FDEN40VD	FDEN50VD	
Outdoor name			FDC71VNX	FDC100VNX	
Power source			1Phase 220-240V 50Hz, 1Phase 220V 60Hz		
Nominal cooling capacity (Min~Max)	ISO-T1(JIS)	kW	7.1 (3.2~8.0)	10.0 (4.0~11.2)	
Nominal heating capacity (Min~Max)	ISO-T1(JIS)	kW	8.0 (3.6~9.0)	11.2 (4.0~12.5)	
Power Consumption	Cooling/Heating	kW	1.98/2.40	3.02/3.18	
COP	Cooling/Heating		3.59/3.33	3.31/3.52	
Energy label	Cooling/Heating		A/C	A/B	
Inrush current (Max. running current)		A	5(17)	5(24)	
Sound level*1 ※	Indoor*2	dB(A)	Hi:39 Me:38 Lo:37		
	Outdoor		Cooling:51 Heating:48 Cooling:48 Heating:50		
Air flow ※	Indoor*2	CMM	Hi:11 Me:9 Lo:7		
	Outdoor		Cooling:60 Heating:50 100		
Indoor unit	Exterior dimensions	Height x Width x Depth	mm 210x1,070x690		
	Net weight		kg 28		
	Air filter, Q'ty		Pocket Plastic net x2 (Washable)		
Remote control(option)			Wired:RC-E4, RCH-E3	Wireless:RCN-E1R	
Outdoor unit	Exterior dimensions	Height x Width x Depth	mm 750X880(+88)X340		
	Net weight		kg 60		
	Ref.amount precharged		kg(m) 2.95(30)		
Range of usage	Ref.piping size	Liquid/Gas	ø 9.52/15.88		
	Ref.piping length		m 50		
	Vertical height difference	O/U is higher		m 30	
		O/U is lower		m 15	
Operating temperature range	Cooling	O/U	-15~43*3		
	Heating	O/U	-20~20		

SPECIFICATIONS

The values are for simultaneous Multi operation.

			Hyper Inverter							
Set model name			FDEN125VNX PVD	FDEN140VNX PVD	FDEN140VNXTVD	FDEN100VSXPVD	FDEN125VSXPVD	FDEN140VSXPVD	FDEN140VSXTVD	
			Twin		Triple	Twin			Triple	
Indoor name			FDEN60VD	FDEN71VD	FDEN50VD	FDEN50VD	FDEN60VD	FDEN71VD	FDEN50VD	
Outdoor name			FDC125VNX	FDC140VNX	FDC140VNX	FDC100VSX	FDC125VSX	FDC140VSX	FDC140VSX	
Power source			1Phase 220-240V 50Hz, 1Phase 220V 60Hz			3Phase 380-415V 50Hz, 3Phase 380V 60Hz				
Nominal cooling capacity (Min~Max)	ISO-T1(JIS)	kW	12.5 (5.0~14.0)	14.0 (5.0~16.0)	14.0 (5.0~16.0)	10.0 (4.0~11.2)	12.5 (5.0~14.0)	14.0 (5.0~16.0)	14.0 (5.0~16.0)	
Nominal heating capacity (Min~Max)	ISO-T1(JIS)	kW	14.0 (4.0~17.0)	16.0 (4.0~18.0)	16.0 (4.0~18.0)	11.2 (4.0~16.0)	14.0 (4.0~18.0)	16.0 (4.0~20.0)	16.0 (4.0~20.0)	
Power Consumption	Cooling/Heating	kW	3.86/3.70	4.78/4.43	4.72/4.38	3.02/3.18	3.86/3.70	4.78/4.43	4.72/4.38	
COP	Cooling/Heating		3.24/3.78	2.93/3.61	2.97/3.65	3.31/3.52	3.24/3.78	2.93/3.61	2.97/3.65	
Energy label	Cooling/Heating		A/A	C/A	C/A	A/B	A/A	C/A	C/A	
Inrush current (Max. running current)		A	5(26)			5(15)				
Sound level*1 ※	Indoor*2	dB(A)	Hi:41 Me:39 Lo:38		Hi:39 Me:38 Lo:37		Hi:41 Me:39 Lo:38		Hi:39 Me:38 Lo:37	
	Outdoor		Cooling:48 Heating:50 Cooling:49 Heating:52		Cooling:49 Heating:52 49		Cooling:48 Heating:50 Cooling:49 Heating:52		Cooling:49 Heating:52	
Air flow ※	Indoor*2	CMM	Hi:18 Me:14 Lo:12		Hi:11 Me:9 Lo:7		Hi:18 Me:14 Lo:12		Hi:11 Me:9 Lo:7	
	Outdoor				100					
Indoor unit	Exterior dimensions	Height x Width x Depth	mm 210x1,320x690		210x1,070x690		210x1,320x690		210x1,070x690	
	Net weight		kg 37		28		37		28	
	Air filter, Q'ty		Pocket Plastic net x2 (Washable)							
Remote control(option)			Wired:RC-E4, RCH-E3						Wireless:RCN-E1R	
Outdoor unit	Exterior dimensions	Height x Width x Depth	mm 1,300x970x370							
	Net weight		kg 105							
	Ref.amount precharged		kg(m) 4.5(30)							
Range of usage	Ref.piping size	Liquid/Gas	ø 9.52/15.88							
	Ref.piping length		m 100							
	Vertical height difference	O/U is higher		m 30						
		O/U is lower		m 15						
Operating temperature range	Cooling	O/U	-15~43*3							
	Heating	O/U	-20~20							

The data are measured under the following conditions(ISO-T1).

Cooling:Indoor temp. of 27°CDB, 19°CWB, and outdoor temp. of 35°CDB. Heating:Indoor temp. of 20°CDB, and outdoor temp. of 7°CDB, 6°CWB.

*1 : Indicates the value in an anechoic chamber. During operation these values are somewhat higher due to ambient conditions.

*2 : The values are for one indoor unit operation.

*3 : If a cooling operation is conducted when the outdoor air temperature is -5°C or lower, the outdoor unit should be installed at a place where it is not influenced by natural wind. If wind blows, the low pressure will drop and compressor frequency will increase, this will cause the capacity to drop and may cause the unit to break down.

※ Powerful-Hi can be selected. Sound level: 71/100VNX PVD 46dB, 100VSXPVD 46dB, 125/140VNX PVD 50dB, 125/140VSXPVD 50dB, 140VNXTVD 46dB, 140VSXTVD 46dB
Air flow: 71/100VNX PVD 13CMM, 100VSXPVD 13CMM, 125/140VNX PVD 22CMM, 125/140VSXPVD 22CMM, 140VNXTVD 13CMM, 140VSXTVD 13CMM

SPECIFICATIONS The values are for simultaneous Multi operation.

			Micro Inverter							
Set model name			FDEN100VNPVD	FDEN125VNPVD	FDEN140VNPVD	FDEN140VNTVD	FDEN100VSPVD	FDEN125VSPVD		
			Twin			Triple		Twin		
Indoor name			FDEN50VD	FDEN60VD	FDEN71VD	FDEN50VD	FDEN50VD	FDEN60VD		
Outdoor name			FDC100VN	FDC125VN	FDC140VN	FDC140VN	FDC100VS	FDC125VS		
Power source			1Phase 220-240V 50Hz, 1Phase 220V 60Hz				3Phase 380-415V 50Hz, 3Phase 380V 60Hz			
Nominal cooling capacity (Min~Max)	ISO-T1(JIS)	kW	10.0 (4.0~11.2)	12.5 (5.0~14.0)	14.0 (5.0~14.5)	14.0 (5.0~14.5)	10.0 (4.0~11.2)	12.5 (5.0~14.0)		
Nominal heating capacity (Min~Max)	ISO-T1(JIS)	kW	11.2 (4.0~12.5)	14.0 (4.0~16.0)	16.0 (4.0~16.5)	16.0 (4.0~16.5)	11.2 (4.0~12.5)	14.0 (4.0~16.0)		
Power Consumption	Cooling/Heating	kW	3.12/3.28	4.23/3.83	4.87/4.59	4.88/4.58	3.12/3.28	4.23/3.83		
COP	Cooling/Heating		3.21/3.41	2.96/3.66	2.87/3.49	2.87/3.49	3.21/3.41	2.96/3.66		
Energy label	Cooling/Heating		A/B	C/A	C/B	C/B	A/B	C/A		
Inrush current (Max. running current)	A		5(24)				5(15)			
Sound level *1 ※	Indoor*2	dB(A)	Hi:39 Me:38 Lo:37	Hi:41 Me:39 Lo:38			Hi:39 Me:38 Lo:37		Hi:41 Me:39 Lo:38	
	Outdoor		49	Cooling:50 Heating:51	51		49	Cooling:50 Heating:51		
Air flow ※	Indoor*2	CMM	Hi:11 Me:9 Lo:7	Hi:18 Me:14 Lo:12			Hi:11 Me:9 Lo:7		Hi:18 Me:14 Lo:12	
	Outdoor		Cooling:75 Heating:73							
Indoor unit	Exterior dimensions	Height x Width x Depth	mm	210x1,070x690		210x1,320x690		210x1,070x690		
	Net weight	kg		28	37		28	37		
	Air filter, Q'ty	Pocket Plastic net x2 (Washable)								
	Remote control(option)	Wired:RC-E4, RCH-E3 Wireless:RCN-E1R								
Outdoor unit	Exterior dimensions	Height x Width x Depth	mm	845x970x370						
	Net weight	kg		81			83			
	Ref.amount precharged	kg(m)		3.8(30)						
	Ref.piping size	Liquid/Gas	ø	9.52/15.88						
Range of usage	Ref.piping length	m		50						
	Vertical height difference	O/U is higher	m		30					
		O/U is lower	m		15					
	Operating temperature range	Cooling	O/U	-15~43*3						
	Heating	O/U	-20~20							

※ Powerful-Hi can be selected. Sound level: 100VNPVD 46dB, 125/140VNPVD 50dB, 140VNTVD 46dB, 100VSPVD 46dB, 125VSPVD 50dB
Air flow: 100VNPVD 13CMM, 125/140VNPVD 22CMM, 140VNTVD 13CMM, 100VSPVD 13CMM, 125VSPVD 22CMM

SPECIFICATIONS The values are for simultaneous Multi operation.

			Micro Inverter						
Set model name			FDEN140VSPVD	FDEN200VSPVD	FDEN250VSPVD	FDEN140VSTVD	FDEN200VSTVD	FDEN200VSDVD	FDEN250VSDVD
			Twin			Triple		Double Twin	
Indoor name			FDEN71VD	FDEN100VD	FDEN125VD	FDEN50VD	FDEN71VD	FDEN50VD	FDEN60VD
Outdoor name			FDC140VS	FDC200VS	FDC250VS	FDC140VS	FDC200VS	FDC200VS	FDC250VS
Power source			3Phase 380-415V 50Hz, 3Phase 380V 60Hz						
Nominal cooling capacity (Min~Max)	ISO-T1(JIS)	kW	14.0 (5.0~14.5)	20.0 (7.0~22.4)	25.0 (10.0~28.0)	14.0 (5.0~14.5)	20.0 (7.0~22.4)	20.0 (7.0~22.4)	25.0 (10.0~28.0)
Nominal heating capacity (Min~Max)	ISO-T1(JIS)	kW	16.0 (4.0~16.5)	22.4 (7.6~25.0)	28.0 (9.5~31.5)	16.0 (4.0~16.5)	22.4 (7.6~25.0)	22.4 (7.6~25.0)	28.0 (9.5~31.5)
Power Consumption	Cooling/Heating	kW	4.87/4.59	6.47/5.97	9.01/8.05	4.88/4.58	6.40/5.90	7.43/7.26	9.50/8.69
COP	Cooling/Heating		2.87/3.49	3.09/3.75	2.77/3.48	2.87/3.49	3.13/3.80	2.69/3.09	2.63/3.22
Energy label	Cooling/Heating		C/B	B/A	D/B	C/B	B/A	D/D	D/C
Inrush current (Max. running current)	A		5(15)	5(19)	5(22)	5(15)	5(19)		5(22)
Sound level *1 ※	Indoor*2	dB(A)	Hi:41 Me:39 Lo:38	Hi:44 Me:41 Lo:39	Hi:46 Me:44 Lo:43	Hi:39 Me:38 Lo:37	Hi:41 Me:39 Lo:38	Hi:39 Me:38 Lo:37	Hi:41 Me:39 Lo:38
	Outdoor		51	57	Cooling:57 Heating:58	51	57	Cooling:57 Heating:58	
Air flow ※	Indoor*2	CMM	Hi:18 Me:14 Lo:12	Hi:26 Me:23 Lo:21	Hi:29 Me:26 Lo:23	Hi:11 Me:9 Lo:7	Hi:18 Me:14 Lo:12	Hi:11 Me:9 Lo:7	Hi:18 Me:14 Lo:12
	Outdoor		Cooling:75 Heating:73						
Indoor unit	Exterior dimensions	Height x Width x Depth	mm	210x1,320x690		250x1,620x690		210x1,070x690	
	Net weight	kg		37	49		28	37	28
	Air filter, Q'ty	Pocket Plastic net x2 (Washable)							
	Remote control(option)	Wired:RC-E4, RCH-E3 Wireless:RCN-E1R							
Outdoor unit	Exterior dimensions	Height x Width x Depth	mm	845x970x370	1,300x970x370	1,505x970x370	845x970x370	1,300x970x370	1,505x970x370
	Net weight	kg		83	122	140	83	122	140
	Ref.amount precharged	kg(m)		3.8(30)	5.4(30)	7.2(30)	3.8(30)	5.4(30)	7.2(30)
	Ref.piping size	Liquid/Gas	ø	9.52/15.88	9.52/22.22	12.7/22.22	9.52/15.88	9.52/22.22	12.7/22.22
Range of usage	Ref.piping length	m		50	70		50	70	
	Vertical height difference	O/U is higher	m		30				
		O/U is lower	m		15				
	Operating temperature range	Cooling	O/U	-15~43*3					
	Heating	O/U	-20~20	-15~20		-20~20	-15~20		

The data are measured under the following conditions(ISO-T1).
Cooling:Indoor temp. of 27°CDB, 19°CWB, and outdoor temp. of 35°CDB. Heating:Indoor temp. of 20°CDB, and outdoor temp. of 7°CDB, 6°CWB.

*1 : Indicates the value in an anechoic chamber. During operation these values are somewhat higher due to ambient conditions.

*2 : The values are for one indoor unit operation.

*3 : If a cooling operation is conducted when the outdoor air temperature is -5°C or lower, the outdoor unit should be installed at a place where it is not influenced by natural wind. If wind blows, the low pressure will drop and compressor frequency will increase, this will cause the capacity to drop and may cause the unit to break down.

※ Powerful-Hi can be selected. Sound level: 140VSPVD 50dB, 200VSPVD 46dB, 250VSPVD 50dB, 140VSTVD 46dB, 200VSTVD 50dB, 200VSDVD 46dB, 250VSDVD 50dB
Air flow: 140VSPVD 22CMM, 200VSPVD 28CMM, 250VSPVD 32CMM, 140VSTVD 13CMM, 200VSTVD 22CMM, 200VSDVD 13CMM, 250VSDVD 22CMM

MULTI [INDOOR UNIT]

WALL MOUNTED SRK

Only used with outdoor units of TWIN, TRIPLE, MULTI System.



SRK 50/60ZJX-S

Wired remote control



RC-E4
(Option)



RCH-E3
(Option)

Point 1 Jet Air Scroll

We used the same aerodynamic analysis technology as used in developing jet engines.

CFD (computational fluid dynamics), used in blade shape design of jet engines, has been applied to the design of air channels in air conditioners to develop the ideal air channel system (air circulation). The airflow of the jets created in this system enable a large volume of air to be blown with minimum power consumption, yet the air flow is uniform, quiet and reaches points a long distance from the blower.

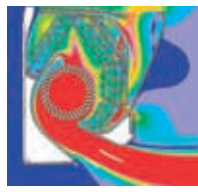

Fast ← → Slow
Colors in the figure show the air speed.

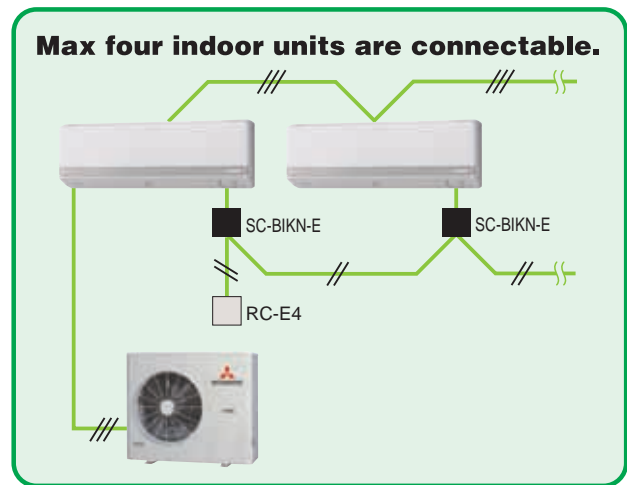

Max four indoor units are connectable.

Point 2 Long Reach Air Flow

Powerful airflow is realized by Jet technology. Good for large living rooms and shops. Increase your comfort.

SRK50/60ZJX-S
(in cooling operation)



15m

Outline drawing (Unit:mm)

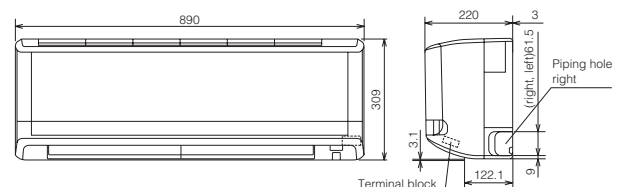
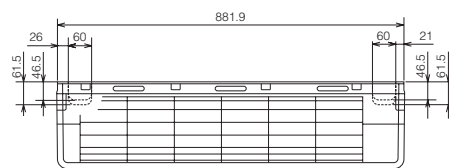

SPECIFICATIONS The values are for simultaneous Multi operation.

			<i>Hyper Inverter</i>					
Set model name			SRK100VNXPJX	SRK125VNXPJX	SRK140VNXZJX	SRK100VSPZJX	SRK125VSPZJX	SRK140VSTZJX
			Twin		Triple	Twin		Triple
Indoor name			SRK50ZJX-S	SRK60ZJX-S	SRK50ZJX-S	SRK50ZJX-S	SRK60ZJX-S	SRK50ZJX-S
Outdoor name			FDC100VNX	FDC125VNX	FDC140VNX	FDC100VSX	FDC125VSX	FDC140VSX
Power source			1Phase 220-240 50Hz, 1Phase 220V 60Hz			3Phase 380-415 50Hz, 3Phase 380V 60Hz		
Nominal cooling capacity (Min~Max)	ISO-T1(JIS)	kW	10.0 (4.0~11.2)	12.5 (5.0~14.0)	14.0 (5.0~16.0)	10.0 (4.0~11.2)	12.5 (5.0~14.0)	14.0 (5.0~16.0)
Nominal heating capacity (Min~Max)	ISO-T1(JIS)	kW	11.2 (4.0~12.5)	14.0 (4.0~17.0)	16.0 (4.0~18.0)	11.2 (4.0~16.0)	14.0 (4.0~18.0)	16.0 (4.0~20.0)
Power Consumption	Cooling/Heating	kW	2.66/2.60	3.60/3.48	3.98/3.68	2.66/2.60	3.60/3.48	3.98/3.68
COP	Cooling/Heating		3.76/4.31	3.47/4.02	3.52/4.35	3.76/4.31	3.47/4.02	3.52/4.35
Energy label	Cooling/Heating		A/A	A/A	A/A	A/A	A/A	A/A
Inrush current (Max. running current)		A	5 (24)			5 (15)		
Sound level*1	Indoor*2	dB(A)	Cooling: Hi:45 Me:38 Lo:26	Heating: Hi:47 Me:38 Lo:26	Cooling: Hi:45 Me:38 Lo:26	Heating: Hi:45 Me:38 Lo:26	Cooling: Hi:47 Me:38 Lo:26	Heating: Hi:45 Me:38 Lo:26
	Outdoor		Cooling:48	Heating:50	Cooling:49	Heating:52	Cooling:48	Heating:50
Air flow	Indoor*2	CMM	Cooling: Hi:13.5 Me:11 Lo:8	Heating: Hi:14.5 Me:12.5 Lo:8.5	Cooling: Hi:13.5 Me:11 Lo:8	Heating: Hi:13.5 Me:11 Lo:8	Cooling: Hi:14.5 Me:12.5 Lo:8.5	Heating: Hi:13.5 Me:11 Lo:8
	Outdoor		Cooling: Hi:16.5 Me:14.5 Lo:10.5	Heating: Hi:17 Me:15 Lo:11	Cooling: Hi:16.5 Me:14.5 Lo:10.5	Heating: Hi:16.5 Me:14.5 Lo:10.5	Cooling: Hi:17 Me:15 Lo:11	Heating: Hi:16.5 Me:14.5 Lo:10.5
Indoor unit	Exterior dimensions	Height x Width x Depth	309x890x220					
	Net weight	kg	15					
	Air filter, Q'ty		Polypropylene net x2 (Washable)					
	Remote control(option)		Wired:RC-E4, RCH-E3 & Interface kit:SC-BIKN-E					
	Exterior dimensions	Height x Width x Depth	1,300x970x370					
Outdoor unit	Net weight	kg	105					
	Ref.amount precharged	kg(m)	4.5(30)					
	Ref.piping size	Liquid/Gas	ø 9.52/15.88					
	Ref.piping length	m	100					
	Vertical height difference	O/U is higher	30					
	O/U is lower	15						
Operating temperature range	Cooling	O/U	-15~43*3					
	Heating	O/U	-20~20					

SPECIFICATIONS The values are for simultaneous Multi operation.

			<i>Micro Inverter</i>					
Set model name			SRK100VNPZJX	SRK125VNPZJX	SRK140VNTZJX	SRK100VSPZJX	SRK125VSPZJX	SRK140VSTZJX
			Twin		Triple	Twin		Triple
Indoor name			SRK50ZJX-S	SRK60ZJX-S	SRK50ZJX-S	SRK50ZJX-S	SRK60ZJX-S	SRK50ZJX-S
Outdoor name			FDC100VN	FDC125VN	FDC140VN	FDC100VS	FDC125VS	FDC140VS
Power source			1Phase 220-240 50Hz, 1Phase 220V 60Hz			3Phase 380-415 50Hz, 3Phase 380V 60Hz		
Nominal cooling capacity (Min~Max)	ISO-T1(JIS)	kW	10.0 (4.0~11.2)	12.5 (5.0~14.0)	14.0 (5.0~14.5)	10.0 (4.0~11.2)	12.5 (5.0~14.0)	14.0 (5.0~14.5)
Nominal heating capacity (Min~Max)	ISO-T1(JIS)	kW	11.2 (4.0~12.5)	14.0 (4.0~16.0)	16.0 (4.0~16.5)	11.2 (4.0~12.5)	14.0 (4.0~16.0)	16.0 (4.0~16.5)
Power Consumption	Cooling/Heating	kW	2.72/2.86	4.25/4.29	4.53/4.05	2.72/2.86	4.25/4.29	4.53/4.05
COP	Cooling/Heating		3.62/3.92	2.94/3.26	3.09/3.95	3.62/3.92	2.94/3.26	3.09/3.95
Energy label	Cooling/Heating		A/A	C/C	B/A	A/A	C/C	B/A
Inrush current (Max. running current)		A	5 (24)			5 (15)		
Sound level*1	Indoor*2	dB(A)	Cooling: Hi:45 Me:38 Lo:26	Heating: Hi:47 Me:38 Lo:26	Cooling: Hi:45 Me:38 Lo:26	Heating: Hi:45 Me:38 Lo:26	Cooling: Hi:47 Me:38 Lo:26	Heating: Hi:45 Me:38 Lo:26
	Outdoor		Cooling:49	Heating:51	Cooling:51	Heating:51	Cooling:49	Heating:51
Air flow	Indoor*2	CMM	Cooling: Hi:13.5 Me:11 Lo:8	Heating: Hi:14.5 Me:12.5 Lo:8.5	Cooling: Hi:13.5 Me:11 Lo:8	Heating: Hi:13.5 Me:11 Lo:8	Cooling: Hi:14.5 Me:12.5 Lo:8.5	Heating: Hi:13.5 Me:11 Lo:8
	Outdoor		Cooling: Hi:16.5 Me:14.5 Lo:10.5	Heating: Hi:17 Me:15 Lo:11	Cooling: Hi:16.5 Me:14.5 Lo:10.5	Heating: Hi:16.5 Me:14.5 Lo:10.5	Cooling: Hi:17 Me:15 Lo:11	Heating: Hi:16.5 Me:14.5 Lo:10.5
Indoor unit	Exterior dimensions	Height x Width x Depth	309x890x220					
	Net weight	kg	15					
	Air filter, Q'ty		Polypropylene net x2 (Washable)					
	Remote control(option)		Wired:RC-E4, RCH-E3 & Interface kit:SC-BIKN-E					
	Exterior dimensions	Height x Width x Depth	845x970x370					
Outdoor unit	Net weight	kg	81				83	
	Ref.amount precharged	kg(m)	3.8(30)					
	Ref.piping size	Liquid/Gas	ø 9.52/15.88					
	Ref.piping length	m	50					
	Vertical height difference	O/U is higher	30					
	O/U is lower	15						
Operating temperature range	Cooling	O/U	-15~43*3					
	Heating	O/U	-20~20					

The data are measured under the following conditions (ISO-T1).
Cooling:Indoor temp. of 27°CDB, 19°CWB, and outdoor temp. of 35°CDB.
Heating:Indoor temp. of 20°CDB, and outdoor temp. of 7°CDB, 6°CWB.

*1 : Indicates the value in an anechoic chamber. During operation these values are somewhat higher due to ambient conditions.

*2 : The values are for one indoor unit operation.

*3 : If a cooling operation is conducted when the outdoor air temperature is -5°C or lower, the outdoor unit should be installed at a place where it is not influenced by natural wind. If wind blows, the low pressure will drop and compressor frequency will increase, this will cause the capacity to drop and may cause the unit to break down.

OUTDOOR UNIT (1.5-10.0HP)

Hyper Inverter



SRC40ZIX-S
SRC50ZIX-S*
SRC60ZIX-S*
(1.5HP~2.5HP)

*SRC50/60ZIX-S is common for both of outdoor units of SRK50/60ZIX-S (Residential Air-conditioners) and 1.5, 2, 2.5HP of Inverter Packaged Air-Conditioners. Common components make for easy inventory control and the installation procedure will be the same.



FDC71VNX
(3.0HP)

NEW



FDC100VNX
FDC100VSX
(4.0HP)

FDC125VNX
FDC125VSX
(5.0HP)

FDC140VNX
FDC140VSX
(6.0HP)

Micro Inverter



FDC100VN FDC100VS
FDC125VN FDC125VS
FDC140VN FDC140VS
(4.0HP~6.0HP)



FDC200VS
(8.0HP)



FDC250VS
(10.0HP)

Blue Fin (3~10HP)

Due to application of blue coated fins (KS101) for the heat exchanger of new outdoor unit, corrosion resistance has been improved compared to current models.

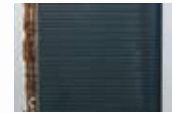

Blue Fin

Base heater kit (option)

This kit is recommended to be used in an area where the lowest temperature drops below 0°C.

CW-H-E
applied for
FDC100~250VN,VS
FDC100~140VNX,VSX



Installation workability

Enhanced installation workability thanks to the extended pipe length – longest level in the industry and pre-charged refrigerant.

Point 1

Piping length – 100m (Hyper Inverter 4~6HP)

Refer to our Technical Manual in detail

Hyper Inverter

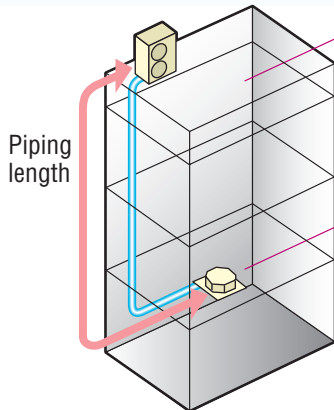

Height difference
(Outdoor higher than Indoor)

HP	Piping length	Height difference
1.5~2.5	30m	20m
3	50m	30m
4-6	100m	30m

Micro Inverter

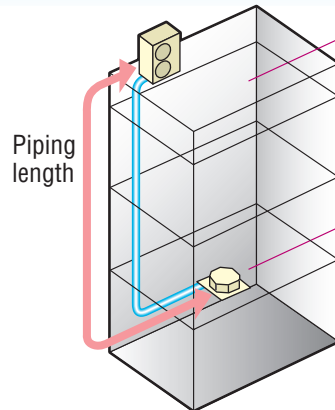

Height difference
(Outdoor higher than Indoor)

HP	Piping length	Height difference
4-6	50m	30m
8-10	70m	30m

Point 2

Refrigerant precharged piping length extending to 30m

Refrigerant precharged piping length extends up to 30m. (1.5~2.5HP:15m)

This eliminates the need to add refrigerant on site, which sets it free from trouble of excessive or insufficient charging of refrigerant, and allows carrying out the installation smoothly.

Control Systems [Individual control]

Remote Control line up

	indoor unit	remote control
wired	all models	RC-E4
		RCH-E3

	indoor unit	remote control
wireless	FDT	RCN-T-36W-E
	FDTC	RCN-TC-24W-ER
	FDUM, FDU	RCN-KIT3-E
	FDEN	RCN-E1R

Wired remote control with weekly timer (option)

RC-E4



The RC-E4 controller enables extensive access to service and maintenance technical data combined with easy to use functions and a clear LCD display.

Weekly timer function as standard

RC-E4 provides (as a standard feature) a weekly timer, which allows one-week operation schedules to be registered. A user can specify up to four times a day to start/stop the air conditioner. (Temperature setting is also possible with the timer).

Timer operation

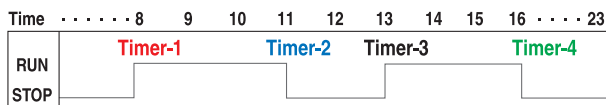

Run hour meters to facilitate maintenance checking

RC-E4 stores operation data when an anomaly occurs and indicates the error on the LCD. It also displays cumulative operation hours of the air conditioner and compressor since commissioning.

Room temperature controlled by the remote control sensor

The temperature sensor is housed in the top section of the remote control unit. This arrangement has improved the sensitivity of the remote control unit's sensor, which permits more finely controlled air conditioning.

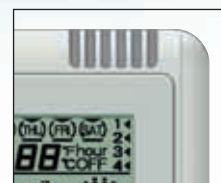

Changeable set temperature ranges

RC-E4 allows the upper and lower limits of a set temperature range to be specified separately.

By adjusting a set temperature range, you can ensure energy saving air conditioning by avoiding excessive cooling or heating.

Changeable range	
Upper limit	20~30°C(effective for heating operation)
Lower limit	18~26°C(effective for non-heating operation)

Simple remote control (option)

RCH-E3 (wired)



Considering specialized usage in hotel rooms, control buttons are limited only to minimum required functions such as ON/OFF, mode, temperature setting and fan speed. It is really simple and easy to use.

RCH-E3 is not applicable to the Individual flap control system and the Flap control system. When RCH-E3 is used, the fan has 3 speed settings (Hi-Me-Lo) only.

Up to 16 units

It can control up to 16 units individually, with pressing the AIR CON No. button.

AUTO restart

This function allows starting the air conditioner automatically when power supply is restored after power failure or by turning on the power switch.

Wireless remote control (option)

For wireless control simply insert the infrared receiver kit on a corner of the panel.

RCN-T-36W-E, RCN-TC-24W-ER

RCN-KIT3-E

RCN-E1R



When wireless remote control is used, the fan has 3 speed settings (Hi-Me-Lo) only.

Thermistor (option)

SC-THB-E3

In case sensor in the indoor units or the remote control sensor can not sense the room temperature correctly, or individual remote control in each room is not required but only sensor is required (as when center control system is in place), install SC-THB-E3 at proper place in the rooms.



Control System SUPERLINK-II

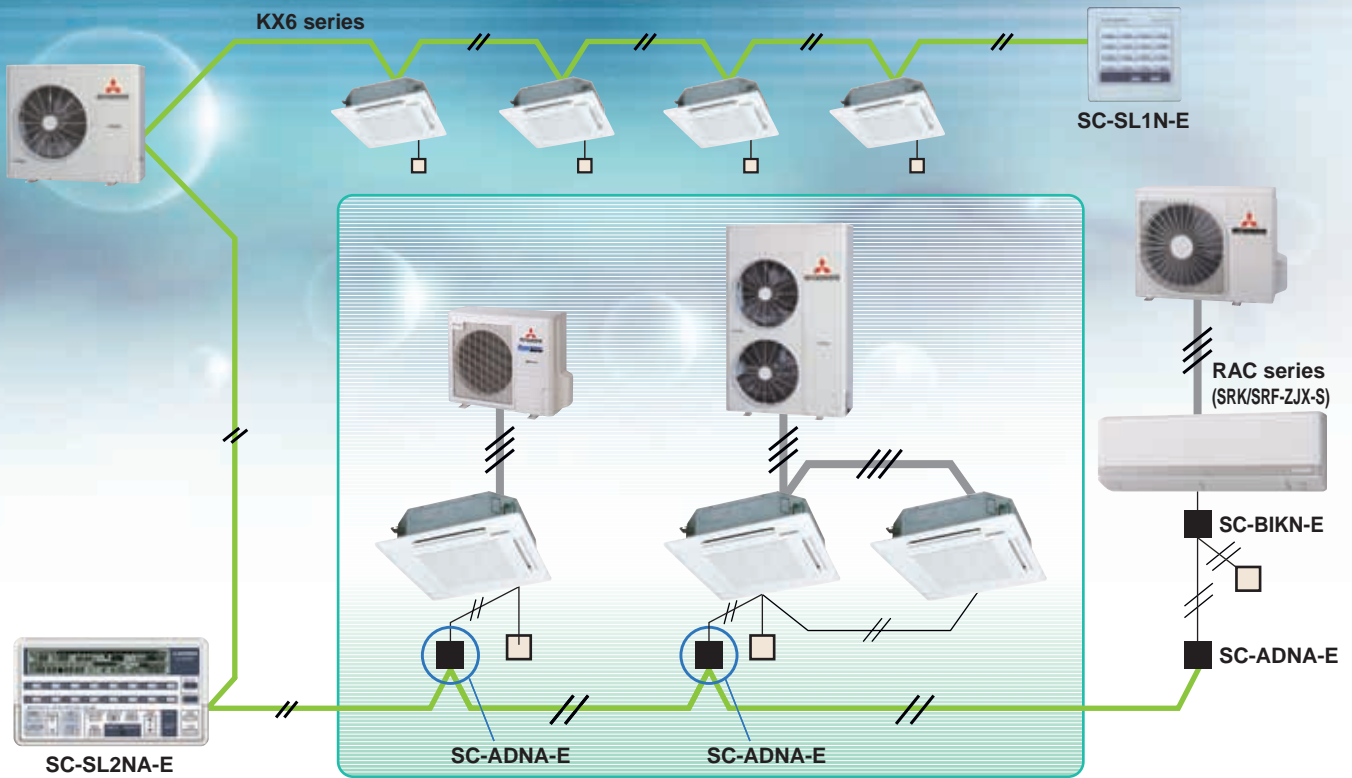

Central Control

SC-SL1N-E



Start/stop control of up to 16 indoor units is possible either individually or collectively. With simple operations, you can effect centralized control.

SC-SL2NA-E

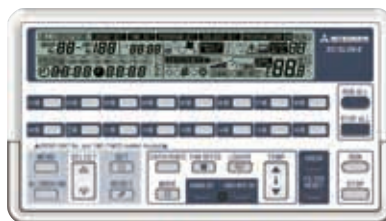

Centralized control of up to 64 indoor units. It can allow connection with a weekly timer without using any interface.

SC-SL3N-AE/BE



Easy operation realized with a large color LCD and touch panel. Up to 128 indoor units can be controlled, when three SUPERLINK-II systems are connected.

PC windows central control

SC-WGWA-A/B

(SC-WGWA-B is with electric power calculation function)



Up to 96 cells (some cells can have two or more indoor units and total number of indoor units can be up to 128 units) are controlled from the Internet Explorer.

Additional engineering service cost etc. is required. Please consult your dealer when using this central control.

BMS interface unit

SC-BGWN-A/B (BACnet gateway)

(SC-WGWN-B is with electric power calculation function)



Up to 96 cells (some cells can have two or more indoor units and total number of indoor units can be up to 128 units) are controlled centrally from a BMS.

Additional engineering service cost etc. is required. In case of SC-BGWN-B, communication test by qualified person regarding electric cost calculation function is required before commissioning. Please consult your dealer when using this gateway.

SC-LGWN-A (LonWorks gateway)



Up to 96 indoor units (48 indoor unit x 2) are linked as an open network! Centrally controlled through LonWorks!

Additional engineering service cost etc. is required. Please consult your dealer when using this gateway.

SUPERLINK E BOARD (SC-ADNA-E)

This board is used when conducting control of the single package (wired remote control unit) 1-type series using a network option (SC-SL1N-E, SC-SL2NA-E, etc).

(1) Functions

- (a) Transmits the settings from the network option to the indoor units.
- (b) Returns the priority indoor unit data in response to a data request from the network option.
- (c) Inspects the error status of connected indoor units and transmits the inspection codes to the network option.
- (d) A maximum of 16 units can be controlled (if in the same operation mode).

(2) Wiring connection diagram

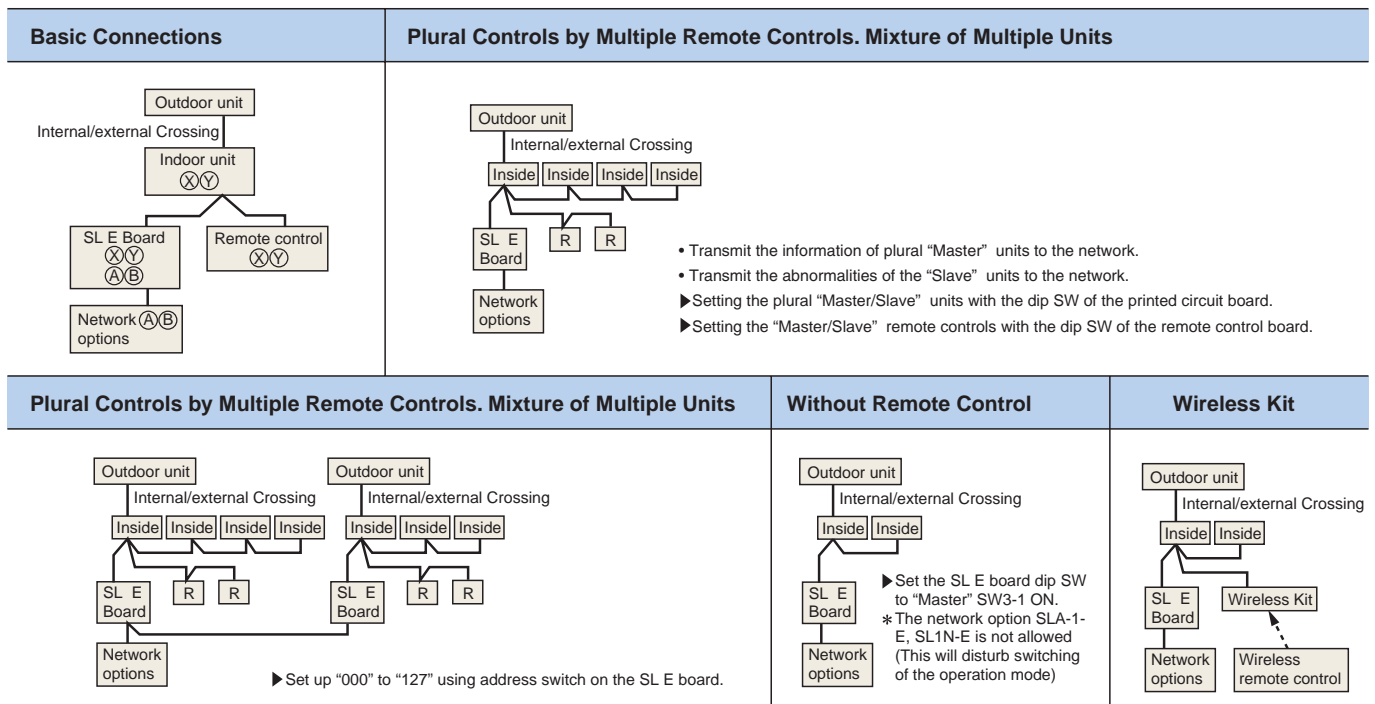
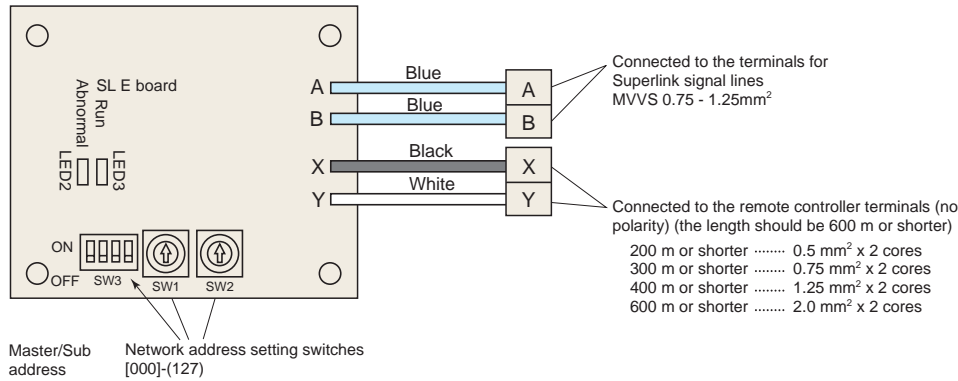

(3) Metal box dimension

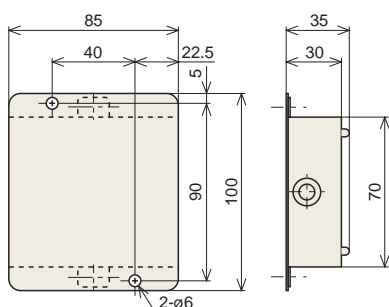

OUTDOOR UNIT DIMENSIONS

FDC100VNX, 100VSX, 125VNX, 125VSX, 140VNX, 140VSX (unit:mm)

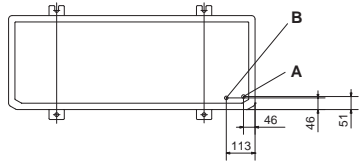

Mark	Item	Dimensions
A	Service valve connection of the attached connecting pipe(gas side)	ø15.88(5/8")(Flare)
B	Service valve connection(liquid side)	ø9.52(3/8")(Flare)
C	Pipe/cable draw-out hole	ø20x3places
D	Drain discharge hole	ø20x3places
F	Anchor bolt hole	M10x4places
F	Cable draw-out hole	ø30x2places(front) ø45(side) ø50(back)

- Notes:
- (1) It must not be surrounded by walls on the four sides.
 - (2) The unit must be fixed with anchor bolts. An anchor bolt must not protrude more than 15mm.
 - (3) Where the unit is subject to strong winds, lay it in such a direction that the blower outlet faces perpendicularly to the dominant wind direction.
 - (4) Leave 1m or more space above the unit.
 - (5) A wall in front of the blower outlet must not exceed the units height.
 - (6) The model name label is attached on the lower right corner of the front panel.
 - (7) Connect the Service valve with local pipe by using the pipe of the attachment. (Gas side only)

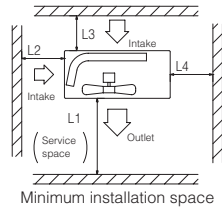
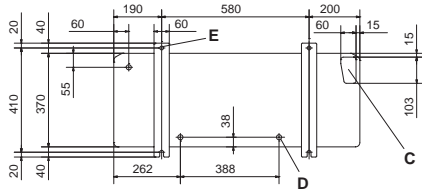
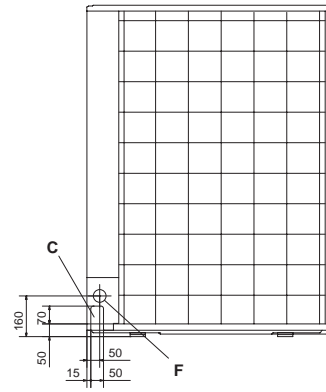
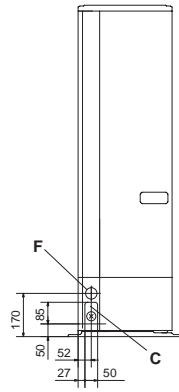
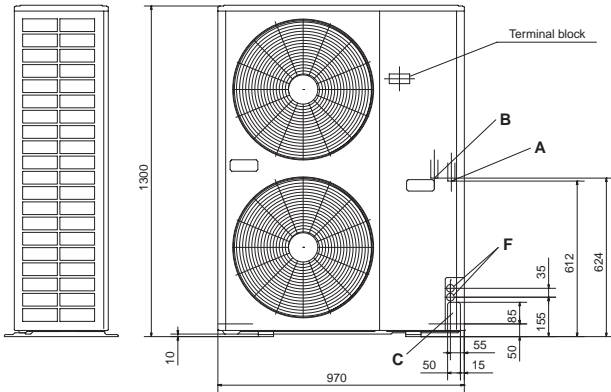

Examples of installation Dimensions	1	2	3
L ₁	Open	Open	500
L ₂	300	5	Open
L ₃	150	300	150
L ₄	5	5	5

SRC40ZIX-S, 50ZIX-S, 60ZIX-S (unit:mm)

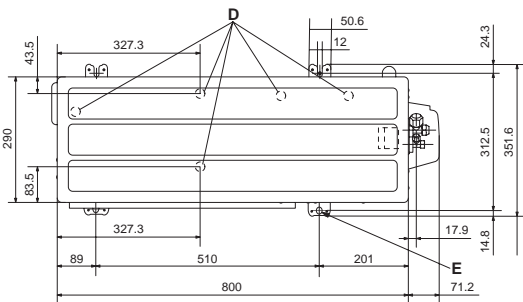
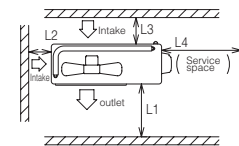
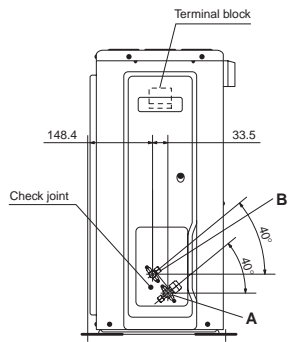
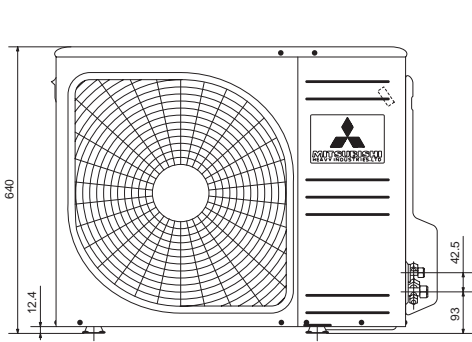

Examples of installation Dimensions	1	2	3
L ₁	Open	280	280
L ₂	100	75	Open
L ₃	100	80	80
L ₄	250	Open	250

Mark	Item	Dimensions
A	Refrigerant gas side pipe connection tap	ø12.7(flare)
B	Refrigerant liquid side pipe connection tap	ø6.35(flare)
D	Drain discharge port	ø20.5x5places
E	Anchor bolt hole	M10x4places

- Notes:
- (1) It must not be surrounded by walls on the four sides.
 - (2) The unit must be fixed with anchor bolts. An anchor bolt must not protrude more than 15mm.
 - (3) Where the unit is subject to strong winds, lay it in such a direction that the blower outlet faces perpendicularly to the dominant wind direction.
 - (4) Leave a 1m or larger space above the unit.
 - (5) A wall in front of the blower outlet must not exceed the units height.
 - (6) The unit name plate is attached on the lower right corner of the front panel.

FDC71VNX (unit:mm)

Mark	Item	
A	Service valve connection (gas side)	ø15.88(5/8") (Flare)
B	Service valve connection (liquid side)	ø9.52(3/8") (Flare)
C	Pipe/cable draw-out hole	
D	Drain discharge hole	ø20x3places
E	Anchor bolt hole	M10x4places

- Notes:
- (1) It must not be surrounded by walls on the four sides.
 - (2) The unit must be fixed with anchor bolts. An anchor bolt must not protrude more than 15mm.
 - (3) Where the unit is subject to strong winds, lay it in such a direction that the blower outlet faces perpendicularly to the dominant wind direction.
 - (4) Leave 1m or more space above the unit.
 - (5) A wall in front of the blower outlet must not exceed the units height.
 - (6) The model name label is attached on the lower right corner of the front.

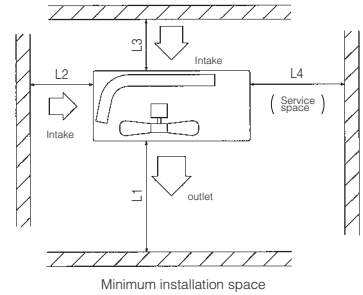
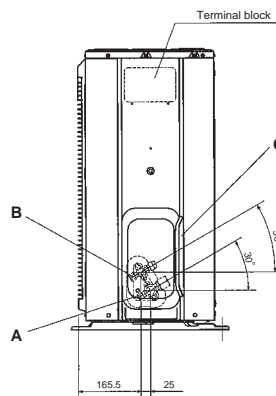
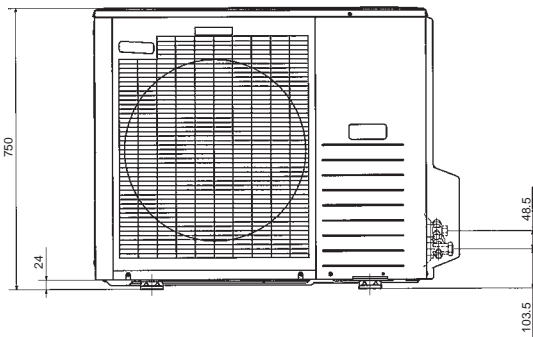
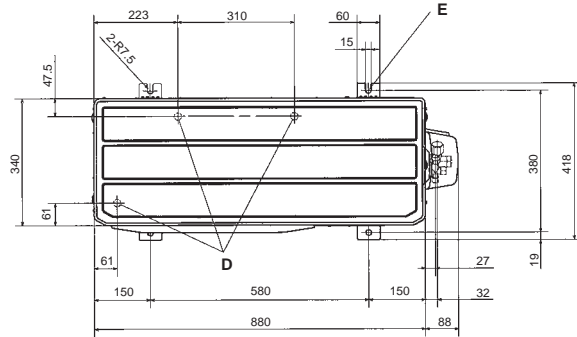

Examples of installation Dimensions	1	2	3
L1	Open	Open	500
L2	300	250	Open
L3	100	150	100
L4	250	250	250

FDC100VN, 125VN, 140VN 100VS, 125VS, 140VS (unit:mm)

Mark	Item	
A	Refrigerant gas side pipe connection tap	ø15.88(flare)
B	Refrigerant liquid side pipe connection tap	ø9.52(flare)
C	Pipe/cable draw-out port	
D	Drain discharge port	ø20.3x3places
E	Anchor bolt hole	M10x4places
F	Cable draw-out port	ø30.3x3places

- Notes:
- (1) It must not be surrounded by walls on the four sides.
 - (2) The unit must be fixed with anchor bolts. An anchor bolt must not protrude more than 15mm.
 - (3) Where the unit is subject to strong winds, lay it in such a direction that the blower outlet faces perpendicularly to the dominant wind direction.
 - (4) Leave a 1m or larger space above the unit.
 - (5) A wall in front of the blower outlet must not exceed the units height.
 - (6) The unit name plate is attached on the lower right corner of the front panel.

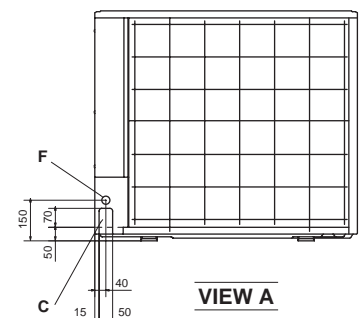
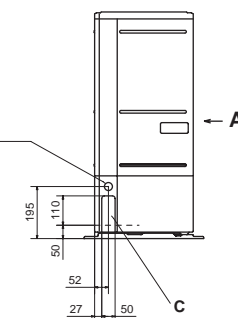
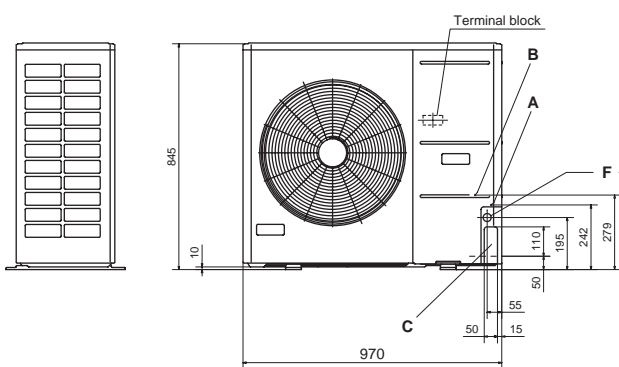
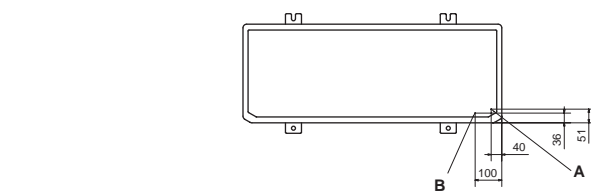

VIEW A

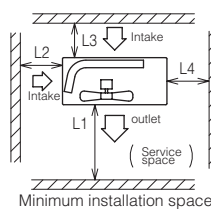
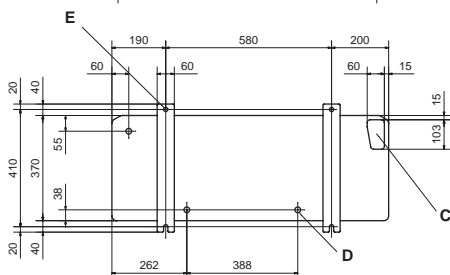

Examples of installation Dimensions	1	2	3
L1	Open	Open	500
L2	300	5	Open
L3	150	300	150
L4	5	5	5

OUTDOOR UNIT DIMENSIONS

FDC200VS (unit:mm)

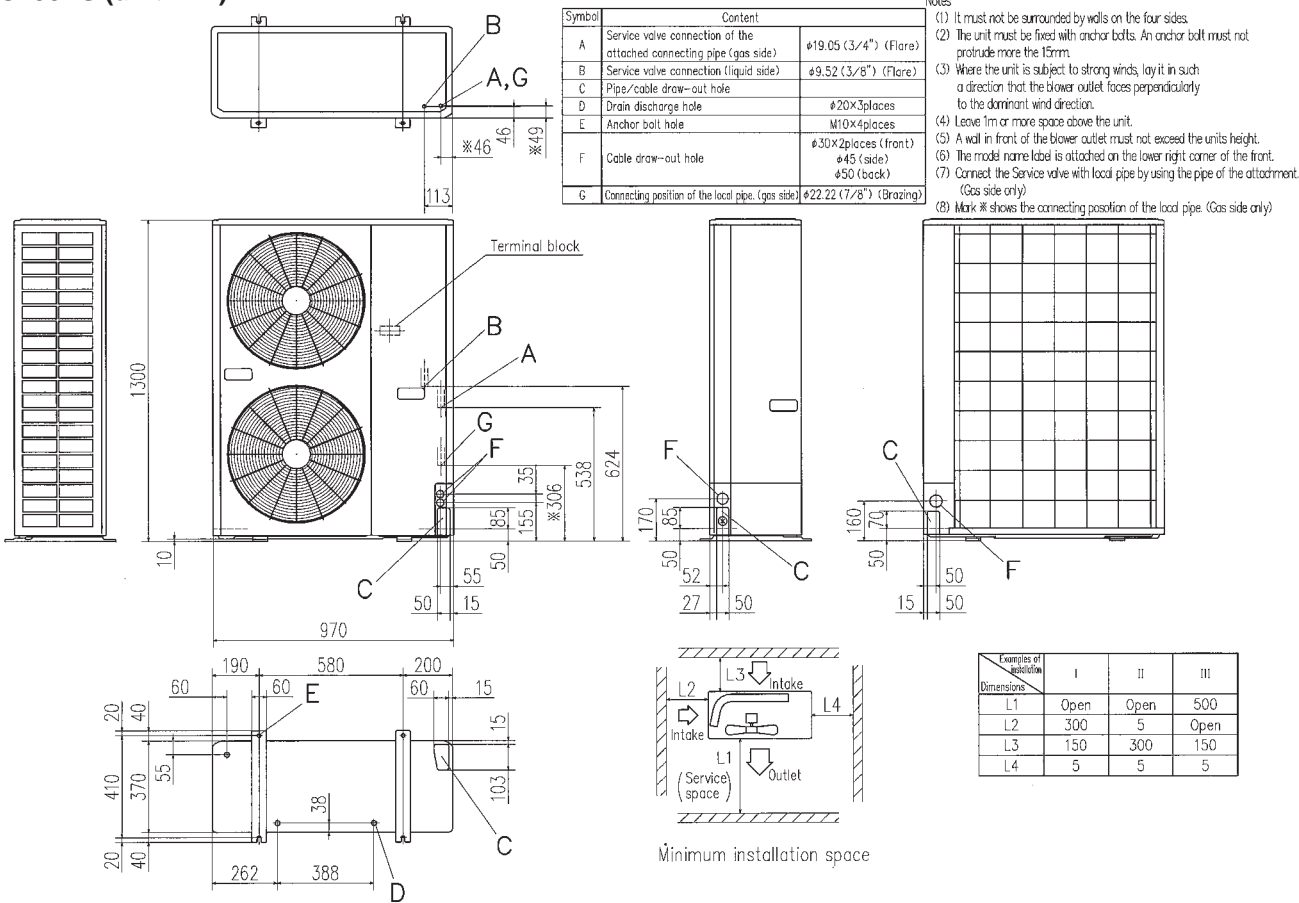

FDC250VS (unit:mm)

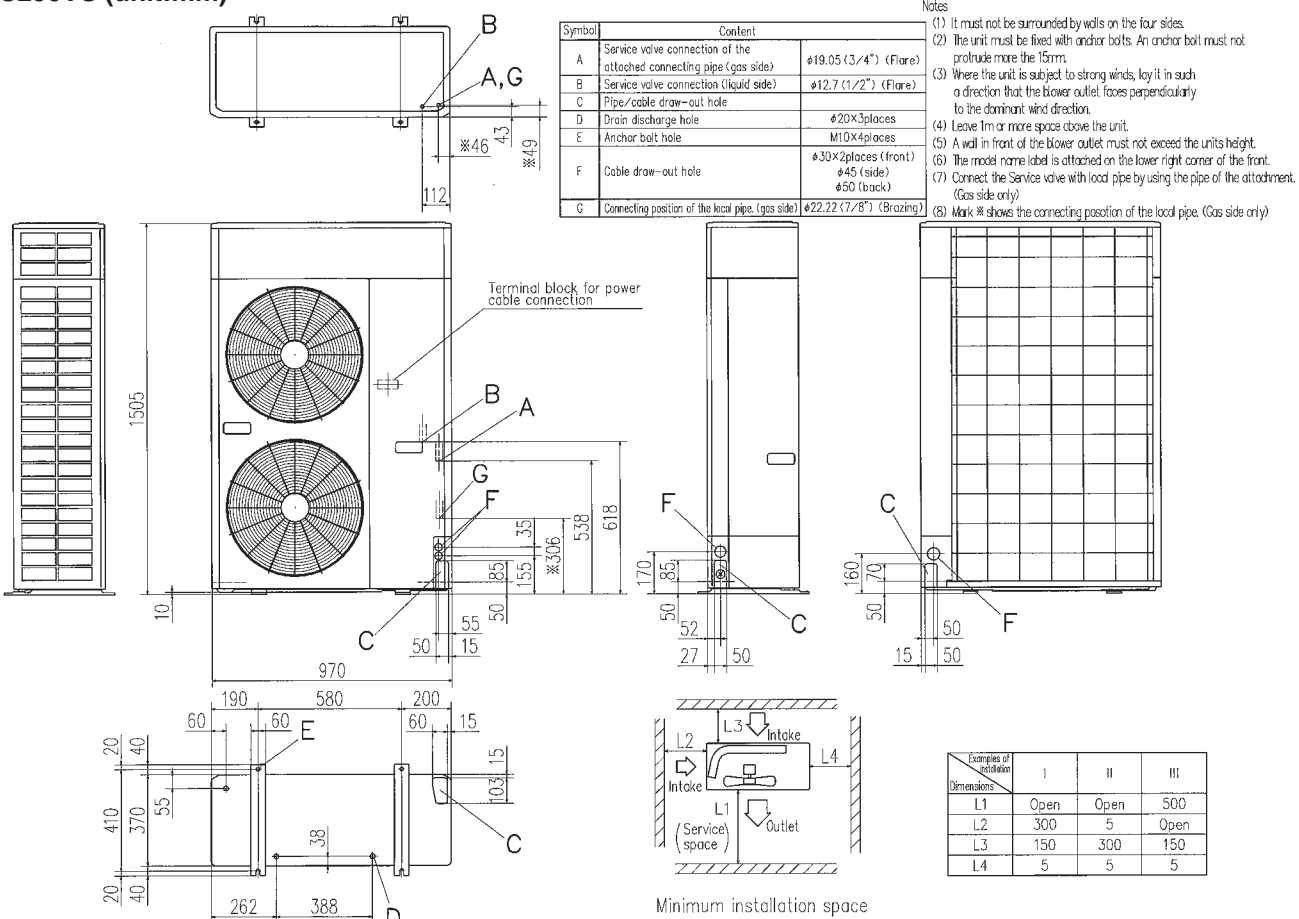

Before starting use

Heating performance

The heating performance values (kW) described in catalog are the values obtained by operating at an outdoor temperature of 7°C and indoor temperature of 20°C as set forth in the ISO Standards. As the heating performance decreases as the outdoor temperature drops, if the outdoor temperature is too low and the heating performance is insufficient, use other heating appliances as well.

Indication of sound values

The sound values are the values (A scale) measured in a chamber such as an anechoic chamber following the ISO Standards. In the actual installation state, the value is normally larger than the values given in the catalog due to the effect of surrounding noise and echo. Take this into consideration when installing.

Use in oil atmosphere

Avoid installing this unit in as atmosphere where oil scatters or builds up, such as in a kitchen or machine factory. If the oil adheres to the heat exchanger, the heat exchanging performance will drop, mist may be generated, and the synthetic resin parts may deform and break.

Use in acidic or alkaline atmosphere

If this unit is used in acidic atmosphere such as hot spring areas having high level of sulfuric gases or in alkaline atmosphere including ammonia or calcium chloride, places where the exhaust of the heat exchanger is sucked in, or at coastal areas where the unit is subject to salt breezes, the outer plate or heat exchanger, etc., will corrode. Please ask a dealer or specialist when you use an air conditioner in places differing from a general atmosphere.

Use in places with high ceilings

If the ceiling is high, install a circulator to improve the heat and air flow distribution when heating.

Refrigerant leakage

The refrigerant (R410A) used for Air conditioner is non-toxic and inflammable in its original state. However, in consideration of a state where the refrigerant leaks into the room, measures against refrigerant leaks must be taken in small rooms where the tolerable level could be exceeded. Take measures by installing ventilation devices, etc.

Use in snowy areas

Take the following measures when installing the outdoor unit in snowy areas.

•Snow prevention

Install a snow-prevention hood so that the snow does not obstruct the air intake port or enter and freeze in the outdoor unit.

•Snow piling

In areas with heavy snow fall, the piled snow could block the air intake port. In this case, a frame that is 50cm or higher than the estimated snow fall must be installed underneath the outdoor unit.

Automatic defrosting device

If the temperature is low, and the humidity is high, frost will stick to the heat exchanger of the outdoor unit. If use is continued, the heating performance will drop.

The "Automatic defrosting device" will function to remove this frost. After heating for approx, three to ten minutes, it will stop, and the frost will be removed. After defrosting, hot air will be blown again.

Servicing the air-conditioner

After the air-conditioner is used for several seasons, dirt will build up in the air-conditioner causing the performance to drop. In addition to regular servicing, we recommend the maintenance contract (charged for) by a specialist.

⚠ Safety Precautions

Air-conditioner usage target

The air-conditioner described in this catalog is a dedicated cooling/heating device for human use.

Do not use it for special applications such as the storage of foodstuffs, animals or plants, precision devices or valuable art, etc.

This could cause the quality of the items to drop, etc.

Do not use this for cooling vehicles or ships. Water leakage or current leaks could occur.

Before use

Always read the "User's Manual" thoroughly before starting use.

Installation

Always commission the installation to a dealer or specialist. Improper installation will lead to water leakage, electric shocks and fires.

Make sure that the outdoor unit is stable in installation. Fix the unit to stable base.

Usage place

Do not install in places where combustible gas could leak or where there are sparks.

Installation in a place where combustible gas could be generated, flow or accumulate, or places containing carbon fibers could lead to fires.



Japan Head Office:
Mitsubishi Heavy Industries Ltd
16-5 2-Chome Kounan Minato-ku Tokyo
108-8215, Japan
www.mhi.co.jp

Our factories are ISO9001 and ISO14001 certified.

Certified ISO 9001



BIWAJIMA PLANT
Mitsubishi Heavy Industries, Ltd.
Air-conditioning & Refrigeration Systems Headquarters
Certificate number: JQA-0709



MITSUBISHI HEAVY INDUSTRIES-
MAHAJAK AIR CONDITIONERS CO., LTD.
Certificate Number: 04101-1999-0913



Mitsubishi Heavy
Industries-Haier (Quingdao)
Air-conditioners Co., Ltd.
Certificate Number: 5170-1996-AQ-RGS-RVA

Certified ISO 14001



BIWAJIMA PLANT
Mitsubishi Heavy Industries, Ltd.
Air-conditioning & Refrigeration Systems Headquarters
Certificate number: JQA-EM256



MITSUBISHI HEAVY INDUSTRIES-
MAHAJAK AIR CONDITIONERS CO., LTD.
Certificate Number: 04104-1999-0913E2



Mitsubishi Heavy
Industries-Haier (Quingdao)
Air-conditioners Co., Ltd.
Certificate number: 01-1999-083



3D Air Sales Limited
01753 495720

HRP Limited
01359 270888